

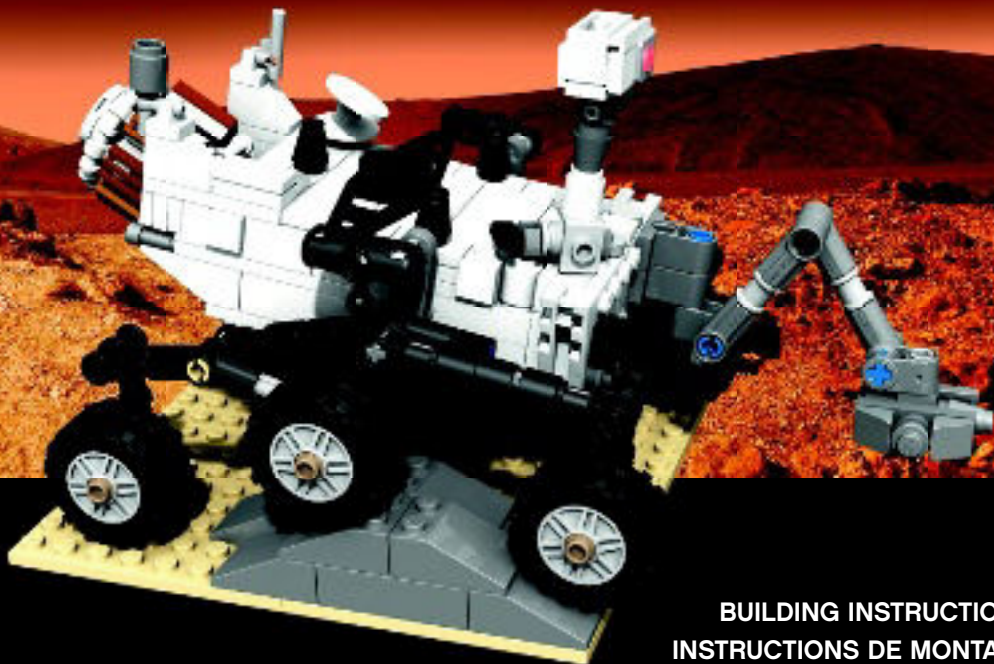









NASA Mars Science Laboratory Curiosity Rover



-  Booklet available in English on
-  Heft in deutscher Sprache erhältlich auf
-  Livret disponible en français sur
-  Folleto disponible en español en
-  Folheto disponível em português em
-  Libretto disponibile in italiano su
-  A füzet magyarul ezen a honlapon olvasható: LEGO.Cuusoo.com

BUILDING INSTRUCTIONS
INSTRUCTIONS DE MONTAGE
INSTRUCCIONES DE CONSTRUCCIÓN

MISSION TO MARS



In 1965, the world eagerly awaited the results of the first spacecraft flyby of Mars. Before then, everything we knew about the Red Planet was based only on what could be seen from telescopes on Earth. Any hopes of finding Martians, or even a hospitable planet, were quickly dashed as Mars appeared to be an arid, cold, and lifeless planet.

It would take almost 50 years and a series of successful space missions to give us a better understanding of this apparently barren planet.

Not only is Mars home to the largest volcano and the deepest canyon in the solar system, but many of its

features appear to be shaped by water, which may, even today, occasionally emerge from below the hostile surface. Water is key to life as we know it, and is one sign that Mars could be a habitat for past or present microbial life...or even human life someday in the future.

This is why Mars continues to intrigue scientists, and why NASA (National Aeronautics and Space Administration) persists in attempting to unlock the secrets of the Red Planet.

FOLLOW THE WATER

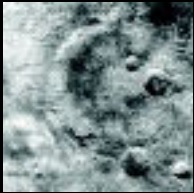

1965

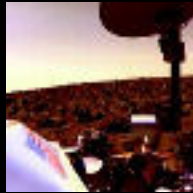

1976



1996



2003



2004

© NASA/JPL-Caltech.

NASA's interest in the Red Planet began soon after it was established in 1958. The very first mission, Mariner 4 (1965), simply flew by Mars, taking as many pictures as possible on its way past. As knowledge and technologies grew, NASA started putting spacecraft in orbit around the planet for long-term global studies. Then, with even more capabilities, NASA spacecraft began to land on the surface, beginning with Viking 1 & 2 (1976). With rovers such as Sojourner (1997), Spirit and Opportunity (2004), and Curiosity (2012), real treks across the planet's surface became possible.

For earlier missions, understanding Mars as a potential habitat for microbial life began with a strategy

of "follow the water." Orbiters, landers, and rovers provided numerous signs of past or present water on Mars. Mars Science Laboratory, with its rover Curiosity, is the latest and most ambitious mission in NASA's Mars Exploration Program. It takes a leap forward in beginning NASA's current Mars exploration strategy: "Seek Signs of Life." In the first year of its mission, Curiosity discovered that Gale Crater once had the right conditions to provide a habitat for microbial life, including the past presence of long-term surface water and at least six key chemical elements that are fundamental chemical building blocks of life.

Curiosity is the most advanced rover ever developed for the Mars program and carries ten times more scientific gear than the earlier Mars rovers. It's about the size of a car, but not quite as fast, with a top speed of only 1.5 inches per second on flat, hard ground. It has six-wheel drive combined with a rocker-bogie suspension system and cameras mounted on a mast to help the mission's team on Earth select exploration targets and driving routes.

Built as a mobile science laboratory, Curiosity is packed with special instruments and cameras for performing a wide range of climatic and geological studies. This includes the ability to gather samples of rocks and soil and analyze them directly in a series of onboard test chambers. With selected instruments

being provided by Russia, Canada, and Spain, this latest mission to Mars has a truly international flavor.

With its sophisticated mobility system and scientific tools, Curiosity's ultimate destination is layered terrain on the slopes of Mt. Sharp at the center of Gale Crater. By exploring these layers, each of which records a specific time in Mars' history, Curiosity will likely uncover the secrets of the Red Planet for many years to come.



© NASA/JPL-Caltech.

THE CURIOSITY ROVER

© NASA/JPL-Caltech.

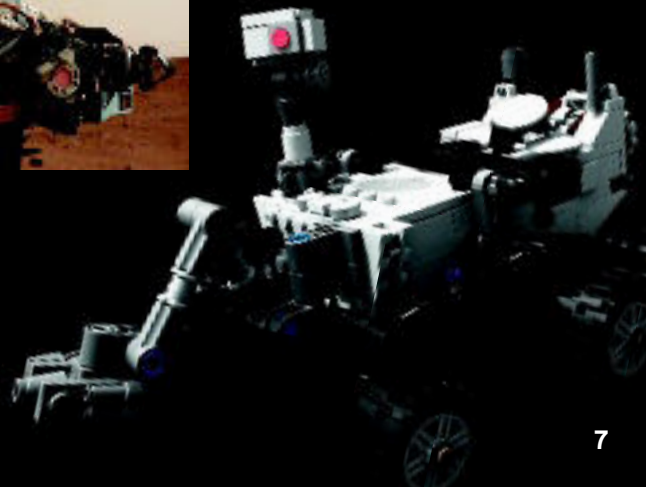

The Curiosity Mars Rover was developed by scientists and engineers from the Jet Propulsion Laboratory, which is a NASA facility managed by the California Institute of Technology (Caltech) in Pasadena, California.

More Information about Curiosity:
mars.nasa.gov/msl
www.nasa.gov

U.S. Design Patent D673,482.

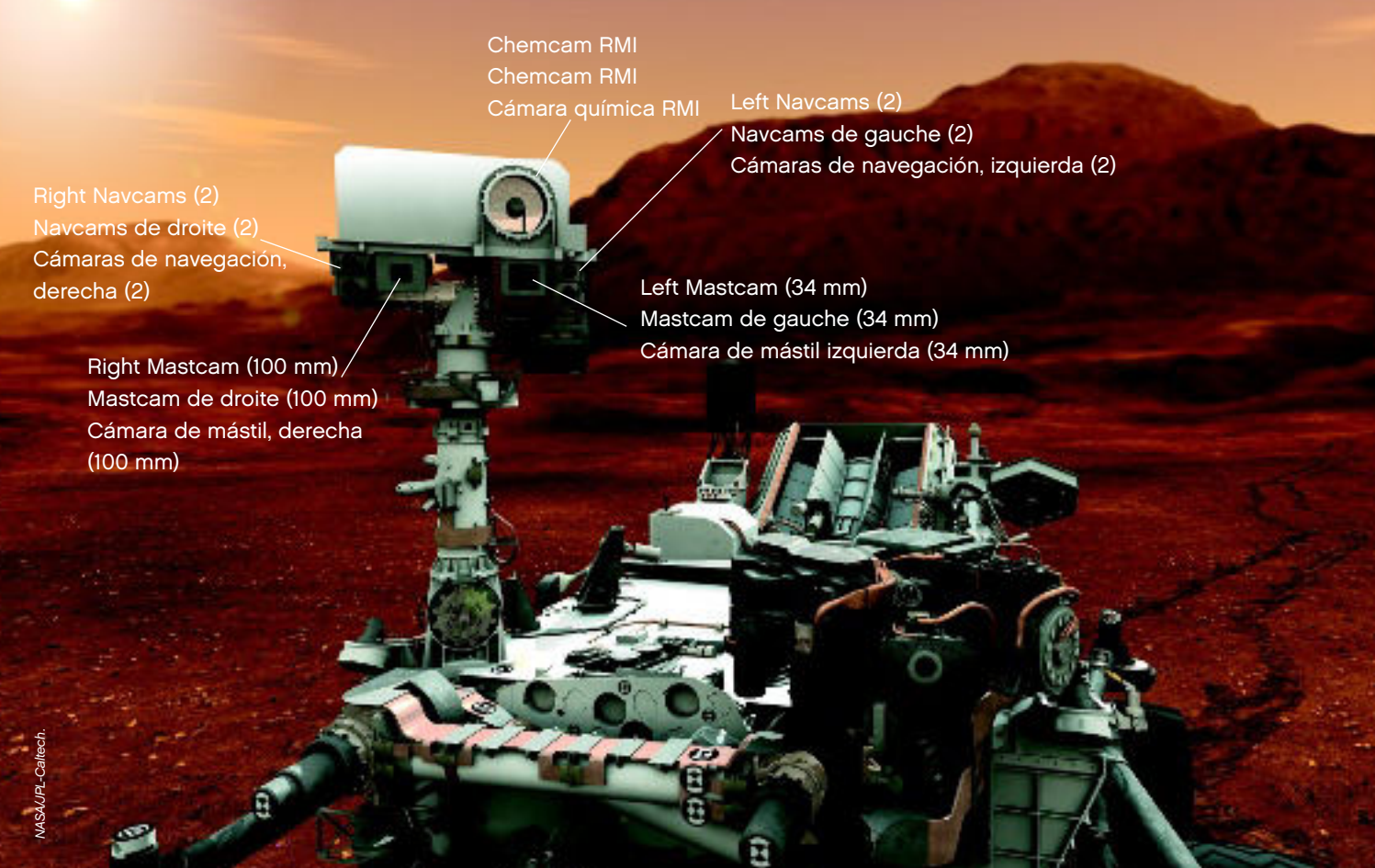

Chemcam RMI
Chemcam RMI
Cámara química RMI

Left Navcams (2)
Navcams de gauche (2)
Cámaras de navegación, izquierda (2)

Right Navcams (2)
Navcams de droite (2)
Cámaras de navegación, derecha (2)

Left Mastcam (34 mm)
Mastcam de gauche (34 mm)
Cámara de mástil izquierda (34 mm)

Right Mastcam (100 mm)
Mastcam de droite (100 mm)
Cámara de mástil, derecha (100 mm)

MMRTG: Multi-mission radioisotope thermoelectric generator
Générateur thermoélectrique à radioisotope multi-mission
Generador termoeléctrico de radioisótopos multimisión

CheMin: Chemistry & Mineralogy X-Ray
Diffraction/X-Ray Fluorescence Instrument
Rayons X de chimie et minéralogie
Instrument de diffraction/fluorescence des rayons X
Equipo de análisis químico y mineralógico por rayos X
Instrumento de fluorescencia y difracción de rayos X

APXS: Alpha Particle X-Ray Spectrometer
Spectromètre à rayons X
Espectrómetro de rayos X de partículas alfa

MARDI: Mars Descent Imager
Caméra de descente sur Mars
Cámara de captación de imágenes del descenso sobre Marte

SAM: Sample Analysis at Mars
Analyse d'échantillons sur Mars
Equipo de análisis de muestras en Marte

MAHLI: Mars Hand Lens Imager
Caméra microscope
Cámara de captación de imágenes para objetos de pequeño tamaño

REMS: Rover Environmental Monitoring Station
Station météorologique
Estación meteorológica para rover

RUHF: Rover ultra high-frequency antenna
Antenne ultra haute fréquence
Antena de ultraalta frecuencia para rover

MMRTG

DAN

MARDI

RUHF

REMS

Inside:

SAM, CheMin

Intérieur :

SAM, CheMin

Interior:

SAM y CheMin

Robotic arm

Bras robotique

Brazo robótico

Turret

Includes APXS, MAHLI

Tourelle

Inclut APXS, MAHLI

Torreta

Incluye APXS y MAHLI

MISSION VERS MARS





En 1965, le monde attendait avec impatience les résultats du premier survol de Mars en vaisseau spatial. Avant cette date, tout ce que nous savions sur la planète rouge était basé uniquement sur les observations effectuées au télescope depuis la Terre. Tout espoir de trouver des Martiens, ou même une planète habitable, fut rapidement anéanti car Mars apparut comme une planète aride, froide et sans vie.

Il fallut presque 50 ans et une série de missions spatiales réussies pour nous permettre de mieux comprendre cette planète apparemment désertique.

Mars abrite non seulement le plus grand volcan et le canyon le plus profond du système solaire, mais

beaucoup de ses caractéristiques semblent avoir été formées par l'eau, qui peut, encore aujourd'hui, jaillir parfois depuis les profondeurs de sa surface hostile. L'eau est la clé de la vie telle que nous la connaissons et est un signe que Mars pourrait constituer un habitat pour une vie microbienne passée ou présente... ou même la vie humaine dans le futur.

C'est pourquoi Mars continue à intriguer les scientifiques et pourquoi l'agence spatiale américaine, la NASA (National Aeronautics and Space Administration), persiste à essayer de percer les secrets de la planète rouge.

SUIVRE L'EAU

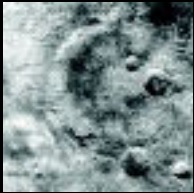

1965

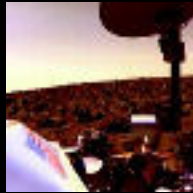

1976



1996



2003



2004

© NASA/JPL-Caltech.

L'intérêt de la NASA pour la planète rouge commença peu après sa fondation, en 1958. La toute première mission, Mariner 4 (1965), se contenta de survoler Mars, en prenant autant de photos que possible. Grâce au développement des connaissances et des technologies, la NASA a commencé à placer des vaisseaux spatiaux en orbite autour de la planète pour mener des études globales à long terme. Leurs capacités accrues permirent aux vaisseaux spatiaux de la NASA de se poser à la surface, en commençant avec Viking 1 et 2 (1976). Des rovers tels que Sojourner (1997), Spirit et Opportunity (2004), et Curiosity (2012), permirent d'effectuer de véritables explorations à la surface de la planète.

Pour les premières missions, la compréhension de Mars comme habitat potentiel pour la vie microbienne

commença avec une stratégie de « suivre l'eau ». Les orbiteurs, les atterrisseurs et les rovers fournirent de nombreux signes d'eau passée ou présente sur Mars. Le laboratoire scientifique pour Mars, avec son rover Curiosity, est la mission la plus récente et la plus ambitieuse du programme d'exploration de Mars de la Nasa. Il fait un bond en avant en commençant la stratégie d'exploration actuelle de la NASA : « À la recherche de traces de vie ». Pendant la première année de sa mission, Curiosity a découvert que le cratère Gale avait eu les conditions adéquates pour fournir un habitat à une vie microbienne, avec notamment la présence passée d'eau à la surface et au moins six éléments chimiques clés fondamentaux pour le développement de la vie.

Curiosity est le rover le plus sophistiqué jamais mis au point pour le programme sur Mars et comprend dix fois plus d'équipements scientifiques que les premiers rovers martiens. Il fait environ la taille d'une voiture, mais il n'est pas aussi rapide, avec une vitesse de pointe de seulement 3,8 cm par seconde sur une surface plate et dure. Il est équipé de six roues motrices combinées à un système de suspension articulée, appelé « rocker-bogie », et de caméras montées sur un mât pour aider l'équipe de la mission sur Terre à sélectionner les cibles d'exploration et les itinéraires.

Construit comme un laboratoire scientifique mobile, Curiosity est plein d'instruments spéciaux et de caméras permettant d'effectuer un vaste éventail d'études climatiques et géologiques. Ceci inclut la capacité de prélever des échantillons de roche et de sol et de les analyser directement dans une série de chambres de test à bord. Certains instruments proviennent de Russie,

du Canada et d'Espagne, cette nouvelle mission vers Mars a donc un aspect réellement international.

Avec son système de mobilité sophistiqué et ses outils scientifiques, la destination ultime de Curiosity est le terrain en couches sur les pentes du Mont Sharp, au centre du cratère Gale. En explorant ces couches, chacune ayant enregistré une époque spécifique de l'histoire de Mars, Curiosity découvrira sans doute les secrets de la planète rouge pendant de nombreuses années à venir.



LE ROVER CURIOSITY

© NASA/JPL-Caltech.

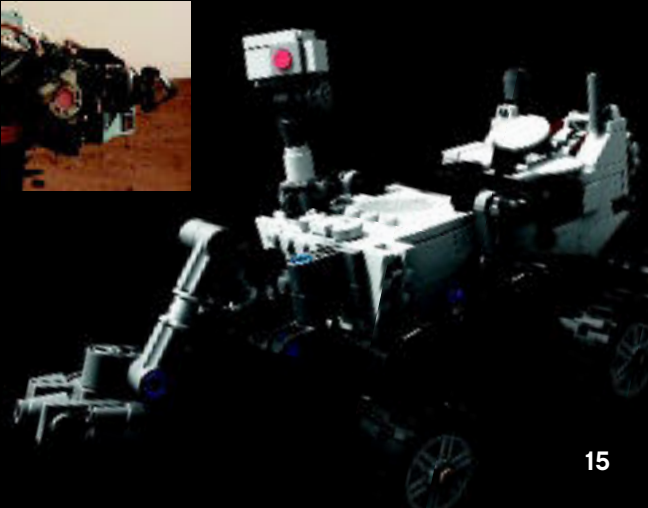
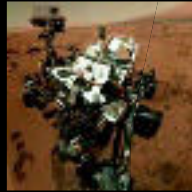

Le rover martien Curiosity a été développé par les scientifiques et les ingénieurs du Jet Propulsion Laboratory, une installation de la NASA gérée par le California Institute of Technology (Caltech) à Pasadena, en Californie.

Plus d'informations sur Curiosity :
mars.nasa.gov/msl
www.nasa.gov

Brevet de modèle américain D673,482.

MISIÓN: MARTE





En 1965, el mundo esperaba con entusiasmo los resultados de la primera nave en sobrevolar la superficie de Marte. Hasta entonces, todo lo que sabíamos sobre el planeta rojo se basaba en lo que nos permitían ver los telescopios desde la Tierra. Las esperanzas de que nos recibiesen los marcianos o se tratase de un planeta habitable se desvanecieron rápidamente: Marte era un planeta árido, frío e inerte.

Serían necesarios casi 50 años y numerosas misiones espaciales para comprender mejor la naturaleza de este planeta, aparentemente yermo.

Marte no es sólo el hogar del volcán más grande y el cañón más profundo del sistema solar, sino que muchos de sus accidentes parecen ser el resultado

de la presencia de agua que, aún hoy, emerge ocasionalmente del subsuelo marciano. El agua es fundamental para la vida tal y como la conocemos, y su presencia en Marte conduce a pensar que el planeta podría haber albergado vida microbiana en el pasado... aunque quizá la albergue también en la actualidad y, en el futuro, pueda permitir incluso la vida humana.

Todos estos son aspectos de Marte que continúan despertando la curiosidad de los científicos y los motivos por los que la NASA (siglas en inglés de la Administración Nacional de la Aeronáutica y del Espacio) persiste en su intento de arrojar luz sobre los secretos del planeta rojo.

RASTROS DE AGUA

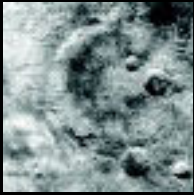

1965

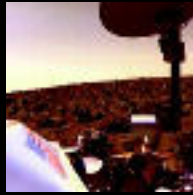

1976



1996



2003



2004

© NASA/JPL-Caltech.

La NASA comenzó a interesarse en el planeta rojo poco después de su fundación, en 1958. La primera misión, denominada Mariner 4 (1965), se limitó a sobrevolar Marte, tomando el mayor número posible de fotografías a su paso por el planeta. Cuando los conocimientos y tecnologías fueron suficientes, la NASA decidió poner en órbita una nave para la ejecución de estudios globales de larga duración. Más tarde, y haciendo uso de tecnologías aún más modernas, la NASA comenzó a enviar naves con el fin de aterrizar en la superficie del cuerpo celeste, comenzando con las sondas Viking 1 y 2 (1976). Con los rovers Sojourner (1997), Spirit y Opportunity (2004) y Curiosity (2012) pudimos por fin pasear por la superficie del planeta.

Las misiones anteriores pusieron de manifiesto que, para determinar las posibilidades de que Marte

albergase vida microbiana, era preciso aplicar una estrategia que permitiera descubrir los «rastros de agua». Los satélites en órbita alrededor del planeta, las naves que se han posado sobre su superficie y los rovers que se han paseado por ella nos han proporcionado numerosas pistas de la existencia actual o pasada de agua en Marte. El Laboratorio Científico de Marte es, con su rover Curiosity, la misión más reciente y ambiciosa del Programa de Exploración de Marte de la NASA. Pero hace falta dar un salto importante para poner en marcha la actual estrategia de exploración de Marte de la NASA: «buscar señales de vida». Durante los primeros años de la misión, el Curiosity descubrió que el cráter Gale presentó alguna vez las condiciones adecuadas para fomentar el desarrollo de vida microbiana: aguas superficiales duraderas y, al menos, seis elementos químicos que se consideran ingredientes clave para la vida.

El Curiosity es el rover más avanzado jamás desarrollado para el programa marciano e incorpora diez veces más aparatos científicos que los rovers anteriores. Posee el tamaño de un automóvil, aunque no es tan rápido: su velocidad máxima es de tan sólo 3,8 cm/s sobre terrenos llanos y firmes. Cuenta con tracción a las seis ruedas, un sistema de suspensión basado en bojes y cámaras instaladas en un mástil que permiten al equipo de la misión seleccionar sus objetivos de exploración y rutas de acceso desde la Tierra.

Desarrollado para actuar como laboratorio científico móvil, el Curiosity está equipado con numerosos instrumentos y cámaras especiales que le permiten llevar a cabo un amplio espectro de estudios

climáticos y geológicos. Como parte de los mismos, es capaz de tomar muestras de roca y tierra, y analizarlas directamente en las cámaras de prueba que contiene. Equipado con instrumentos desarrollados en Rusia, Canadá y España, esta última misión a Marte destila un indudable sabor internacional.

Los últimos destinos del Curiosity son las colinas estratificadas del monte Sharp y el centro del cráter Gale, que alcanzará gracias a su sofisticado sistema de desplazamiento y sus herramientas científicas. Se espera que, al explorar los estratos (cada uno de los cuales representa un período específico de la historia de Marte), el Curiosity sacie nuestra curiosidad acerca del planeta rojo hasta dentro de muchos años.

EL RÓVER CURIOSITY

© NASA/JPL-Caltech.

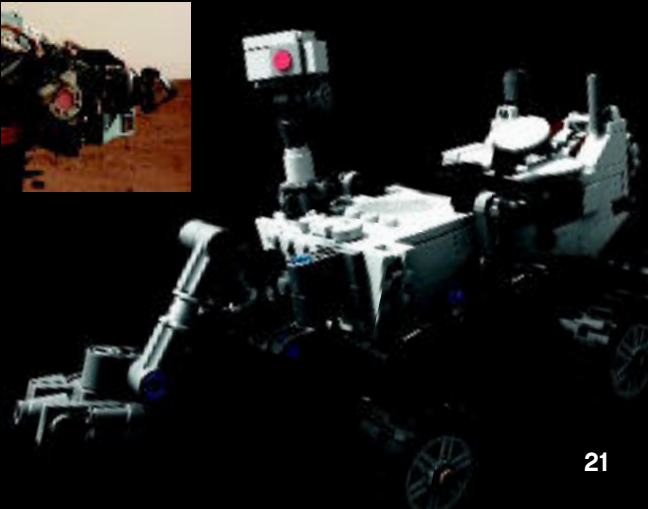
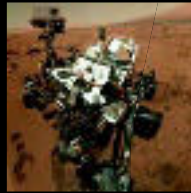

El rover Curiosity fue desarrollado por científicos e ingenieros del Laboratorio de Propulsión a Chorro, perteneciente a la NASA y gestionado por el Instituto Tecnológico de California (Caltech) en Pasadena (California).

Más información acerca del Curiosity:
mars.nasa.gov/msl
www.nasa.gov

Patente de diseño de los EE. UU. D673.482.

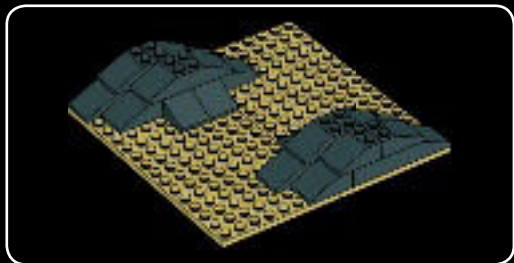

1

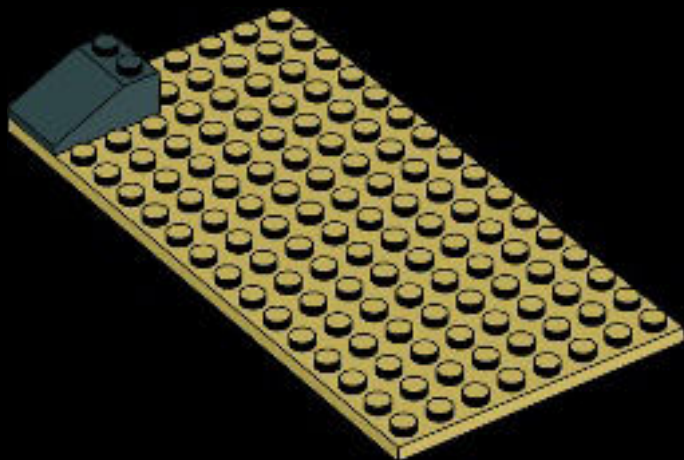



2

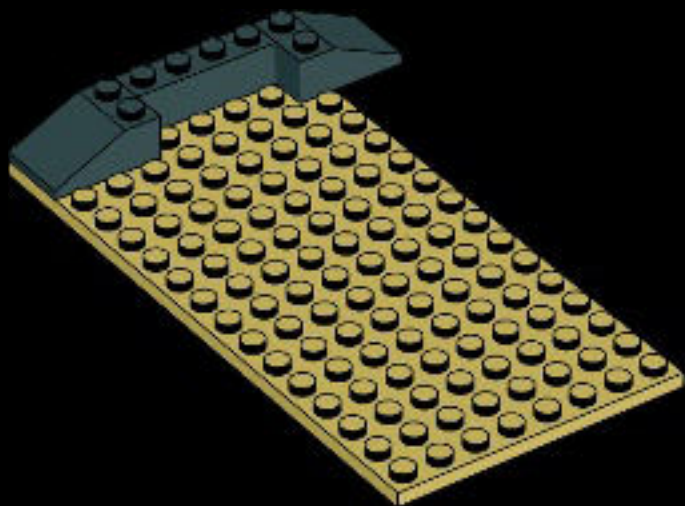

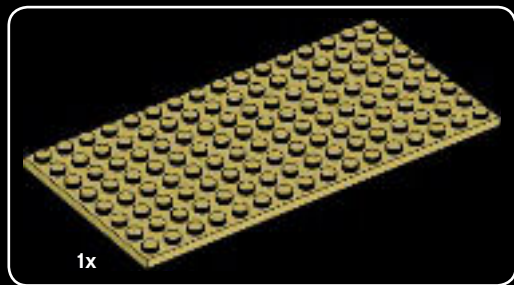

3

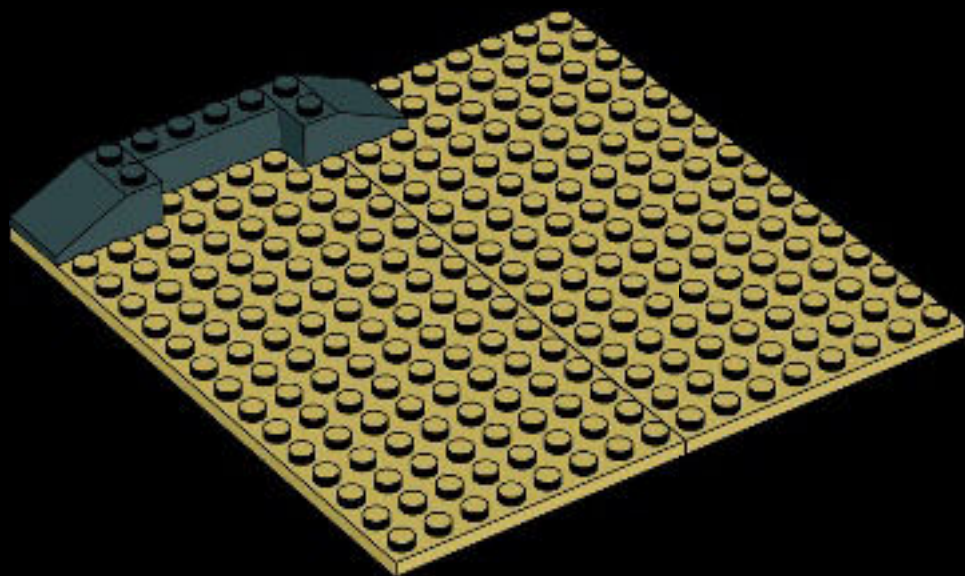



4

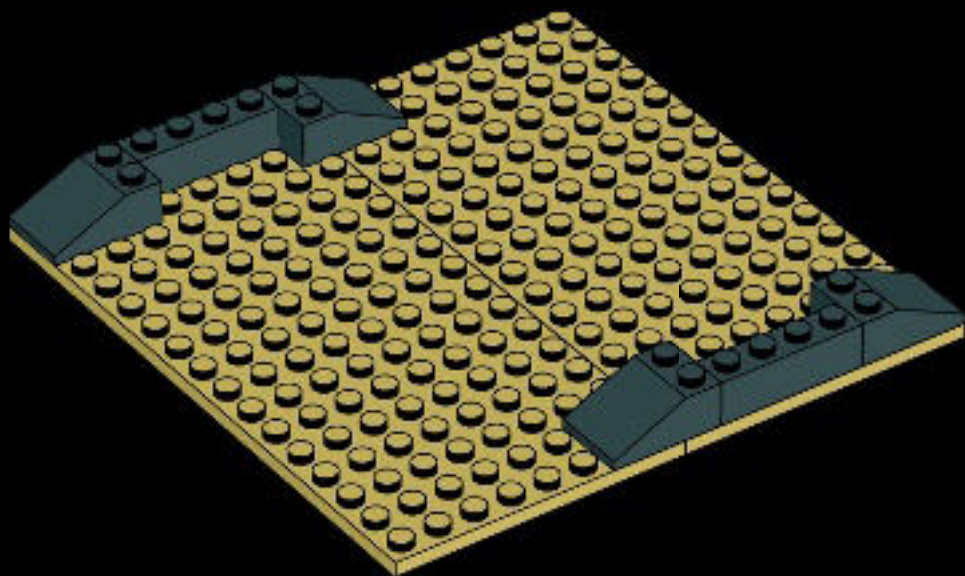



4x

5

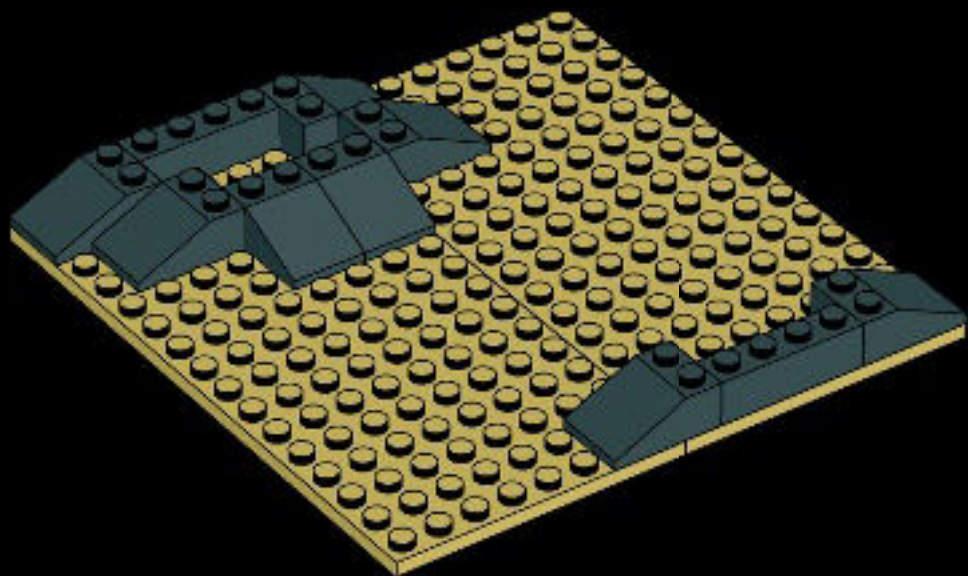



4x

6

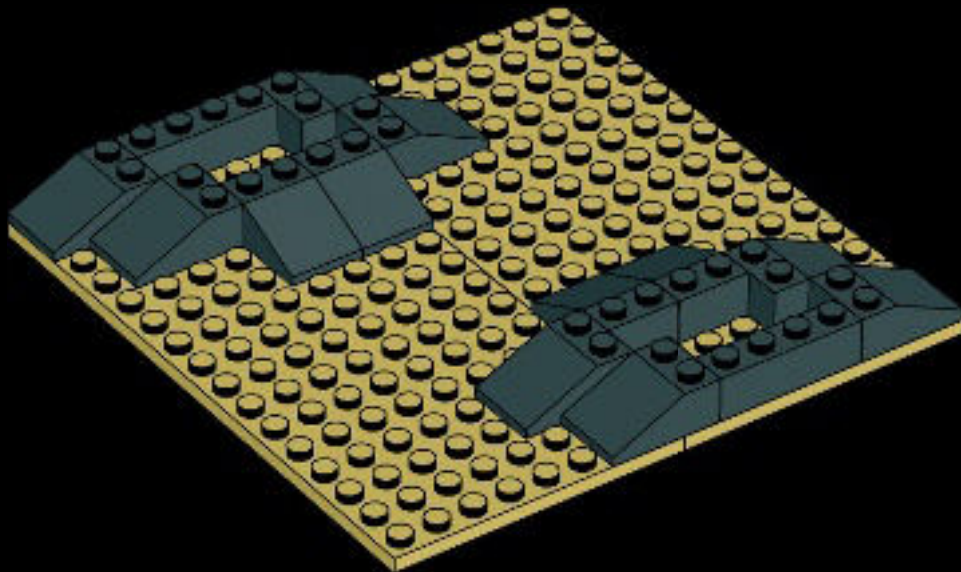

© NASA/JPL-Caltech.

Curiosity can roll over obstacles up to 25 inches (65 cm) high and travel up to about 660 feet (200 m) per day.

Curiosity peut rouler sur des obstacles allant jusqu'à 65 cm de hauteur et parcourir jusqu'à 200 mètres par jour environ.

El Curiosity puede superar obstáculos de hasta 65 cm de altura y recorrer un máximo de, aproximadamente, 200 m al día.



8x

7

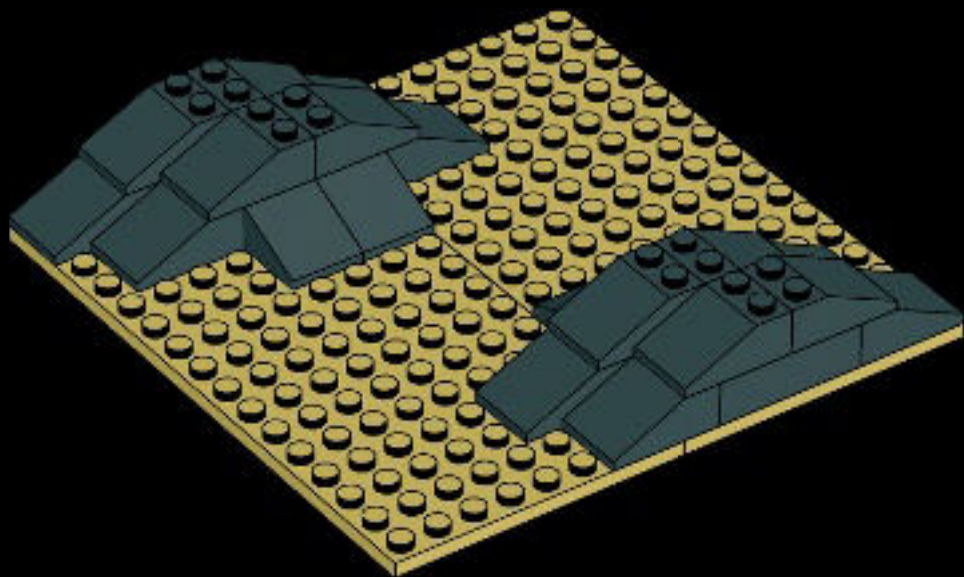

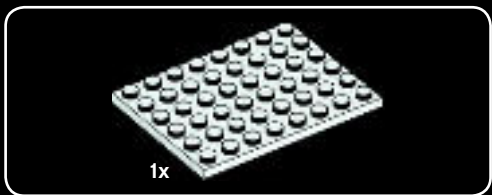
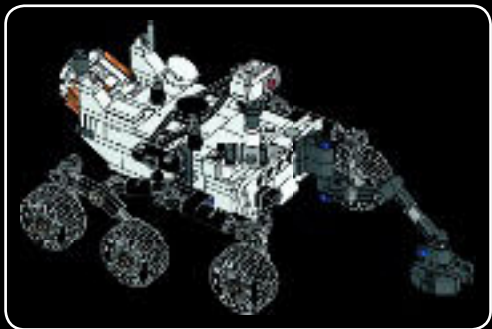

1





1x



1x



1x

2

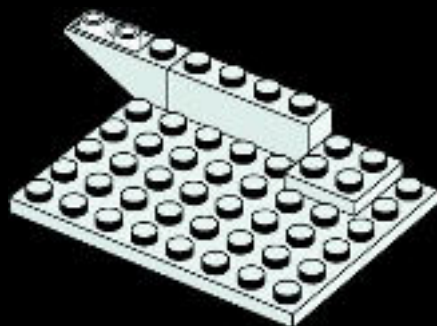



3x

3

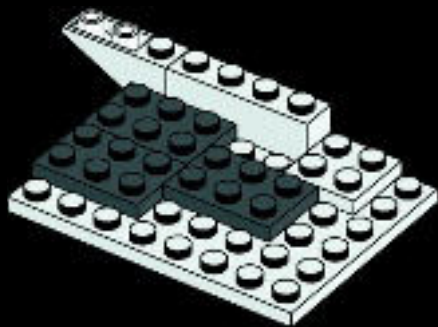

2x

4

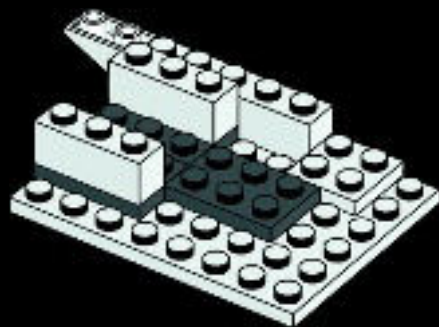



1x



1x



1x

5

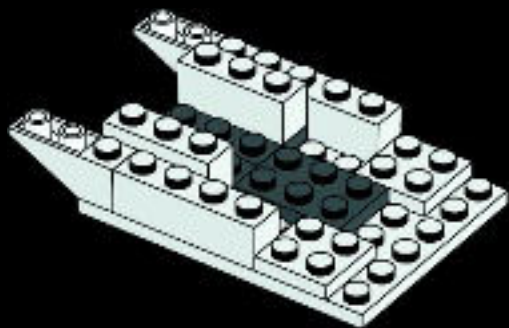

1x

6

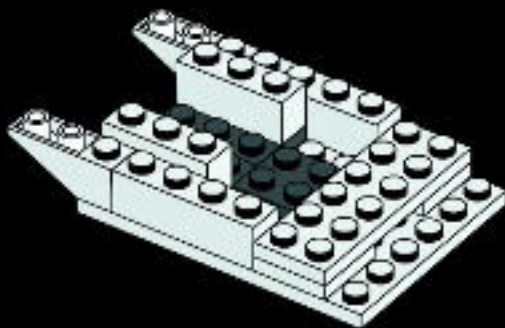



7

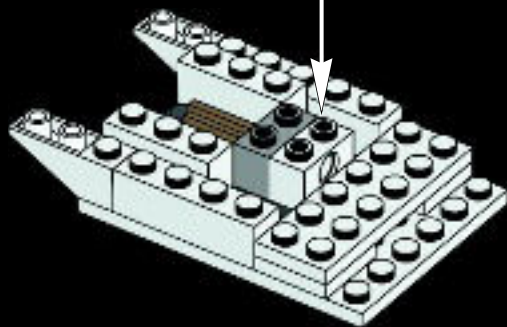
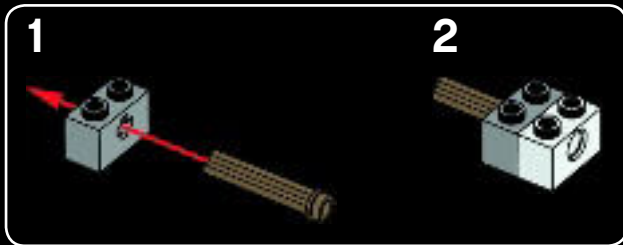



8

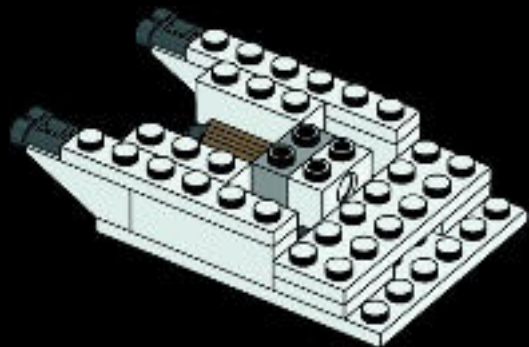

9

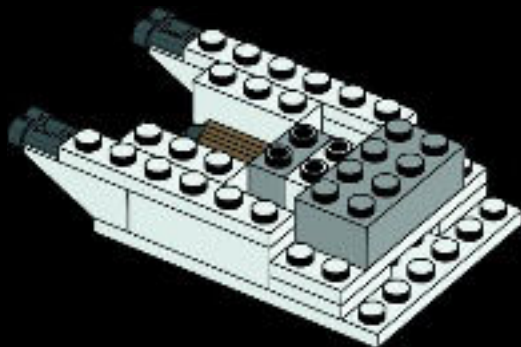



10

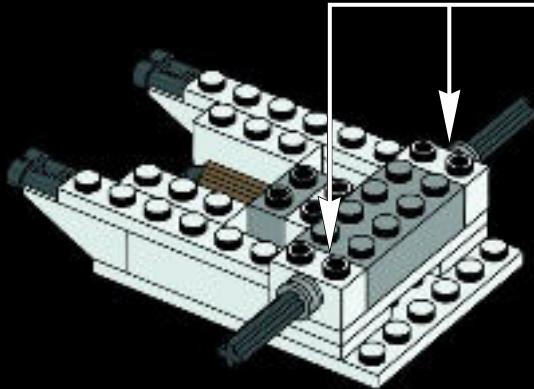
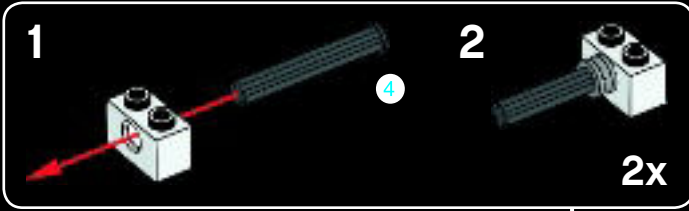

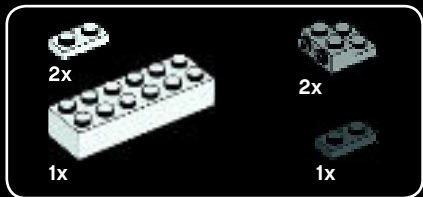

11

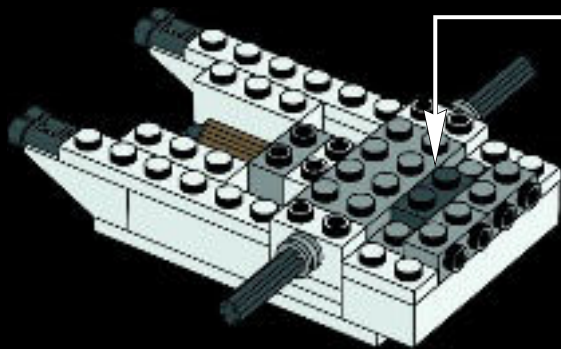
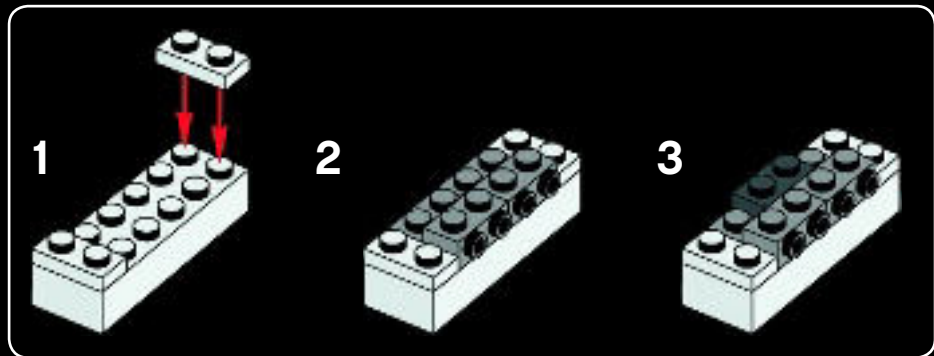



2x



1x

12

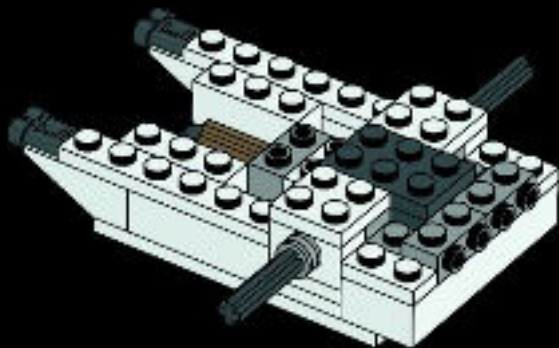



4x



2x



2x

13

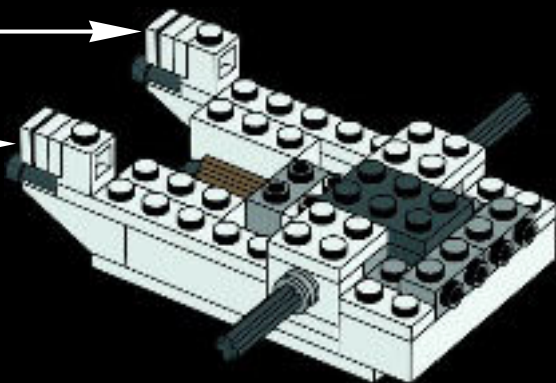
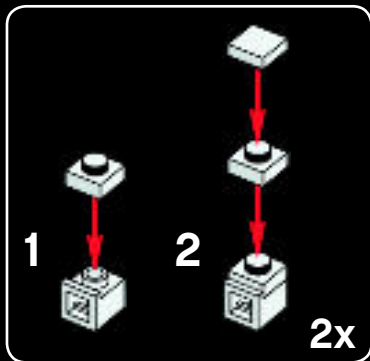



14

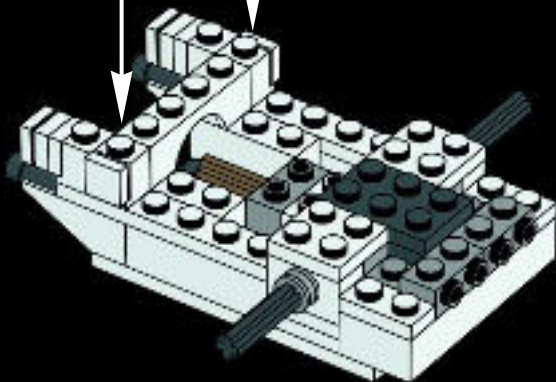
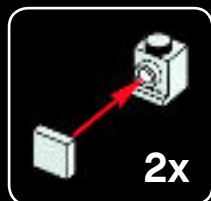



1x



1x

15

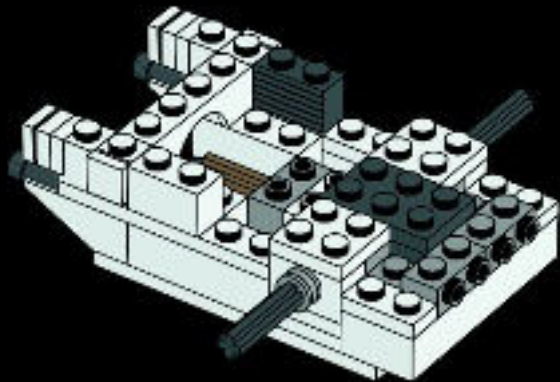

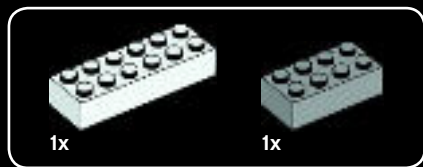

16

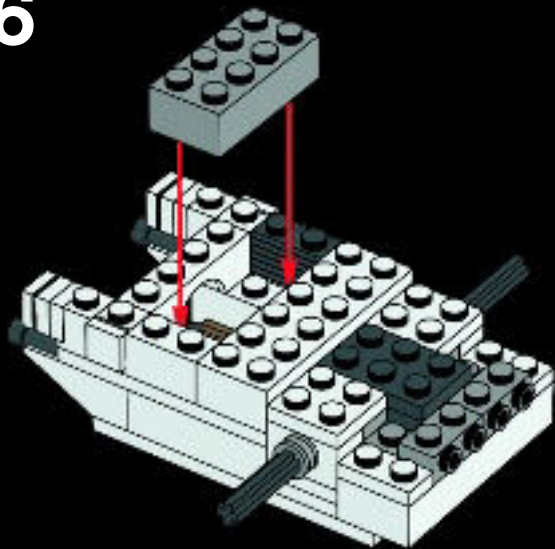

17

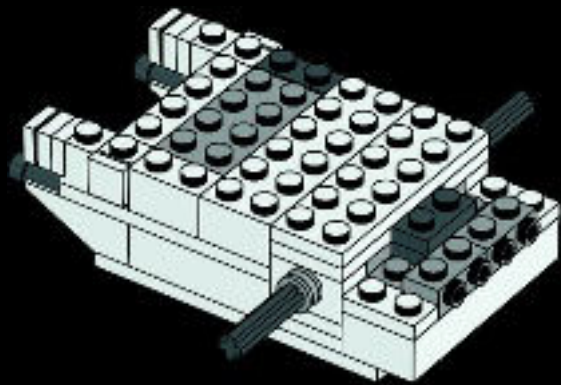

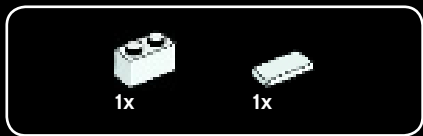

18

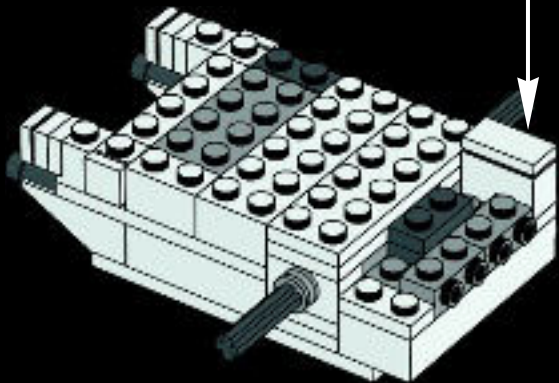
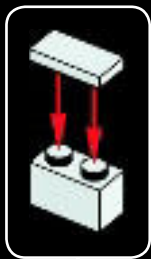

19

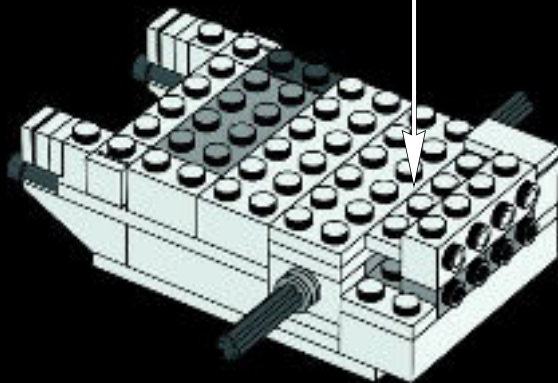



20

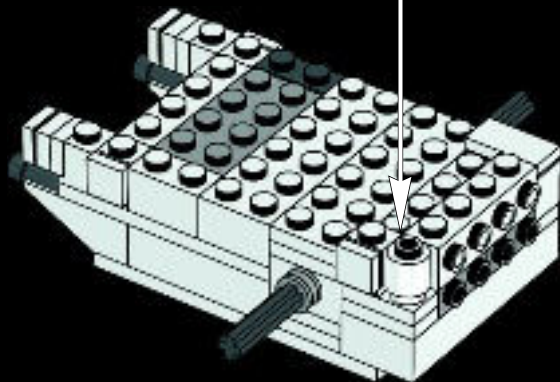



1x



2x



1x

21

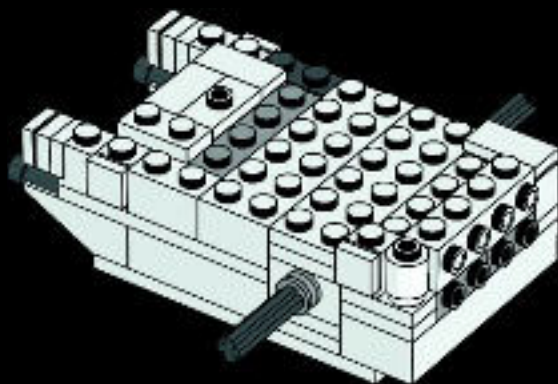



2x

22

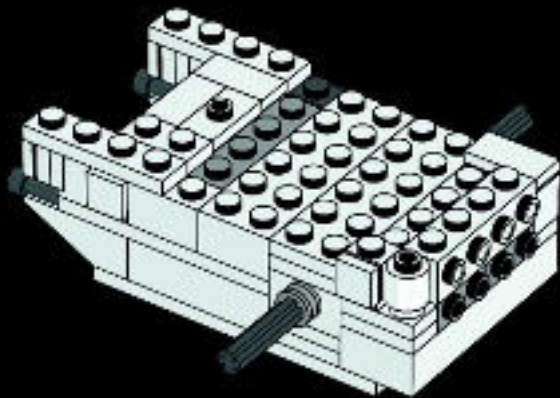

2x



4x



2x



1x

23

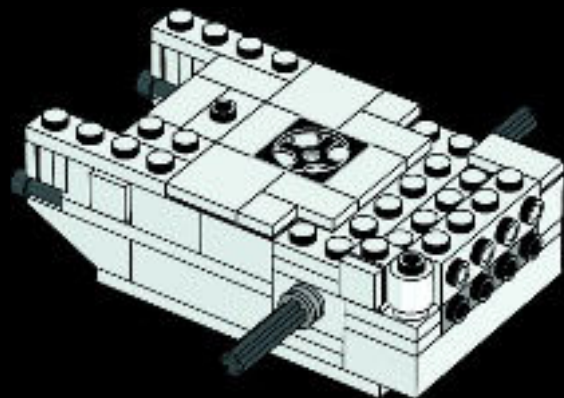



2x



2x

24

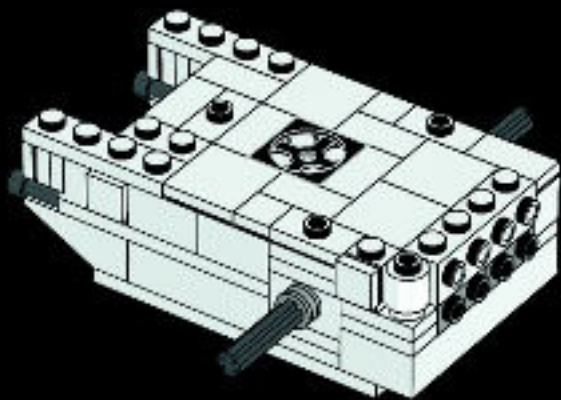

4x

25

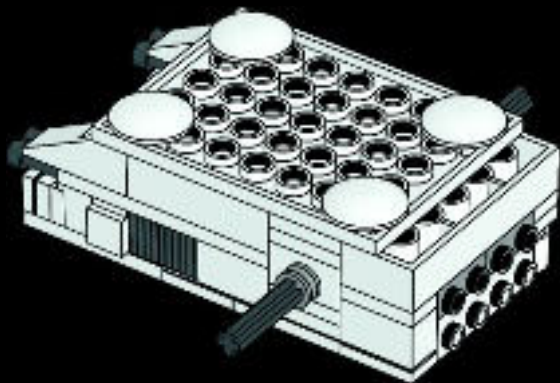



1

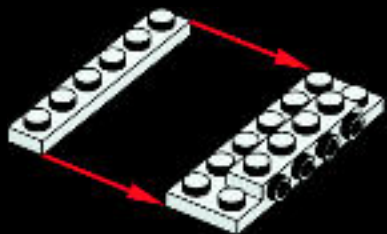

2





3



4

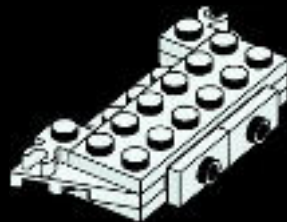

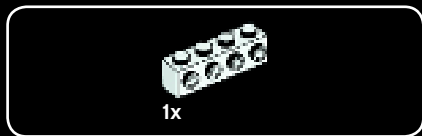

5

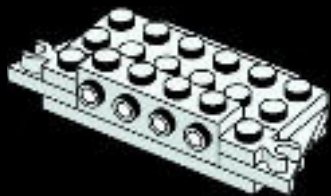

6

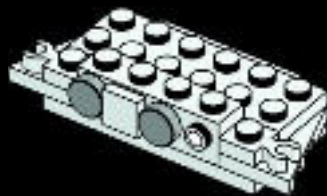

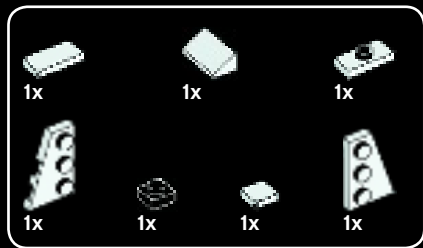

7



8

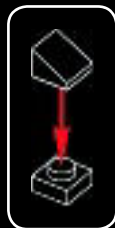

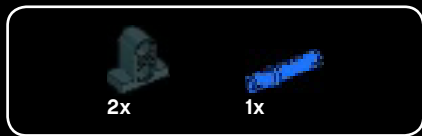

9

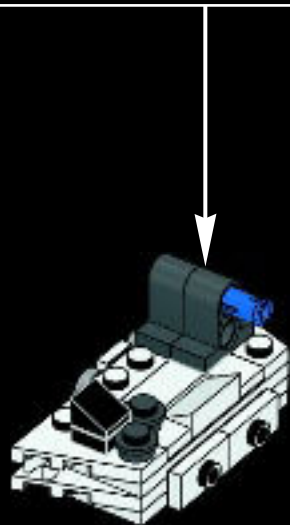
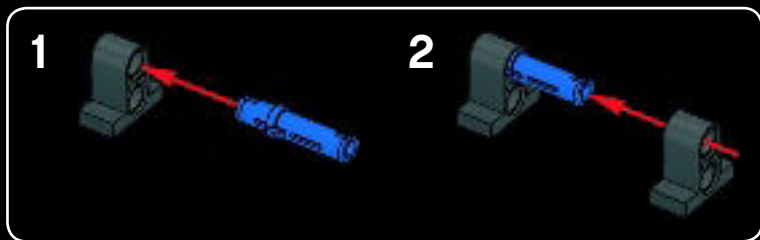



2x

10



26

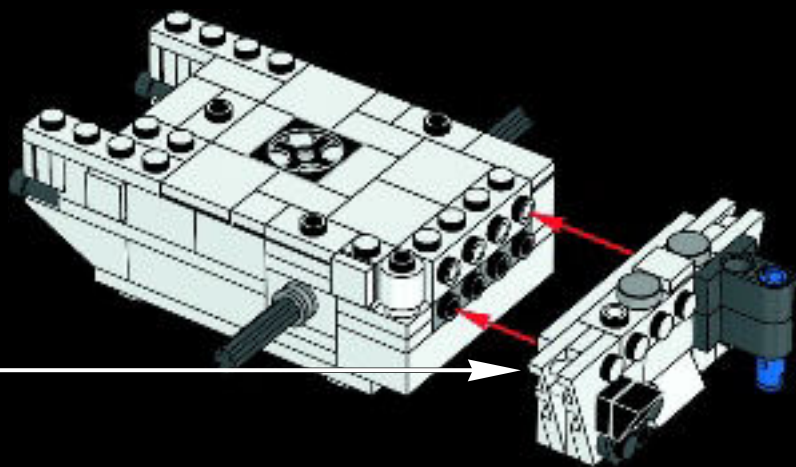



2x

27

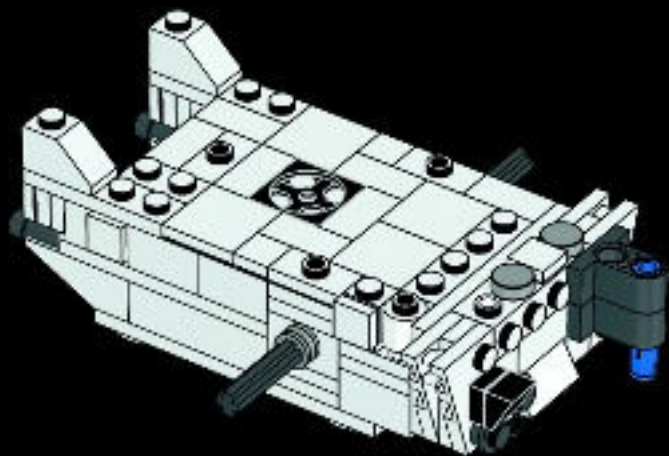



1x



1x



1x



1x

28

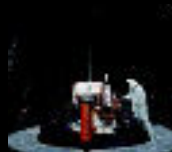
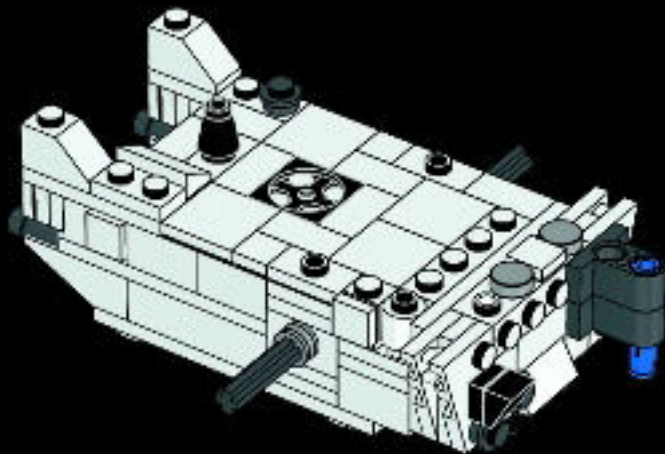

© NASA/JPL-Caltech.

Temperatures on Mars can get as cold as minus 199 degrees Fahrenheit.

Les températures sur Mars peuvent descendre jusqu'à - 128 degrés Celsius.

Las temperaturas mínimas en Marte alcanzan los -128 °C.



1x



1x



2x

29

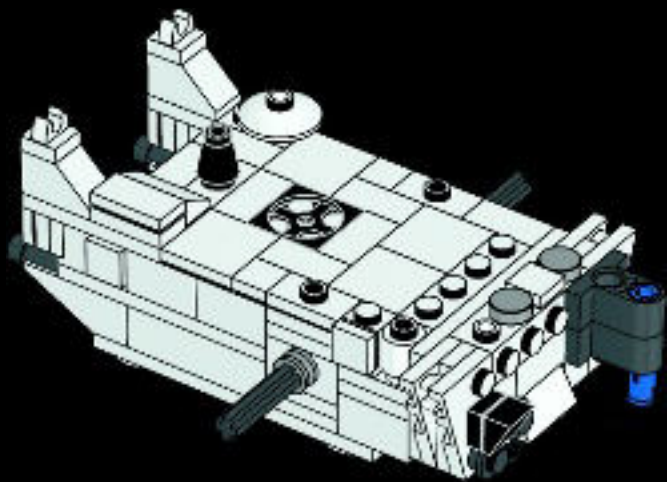



1x



2x



1x

30

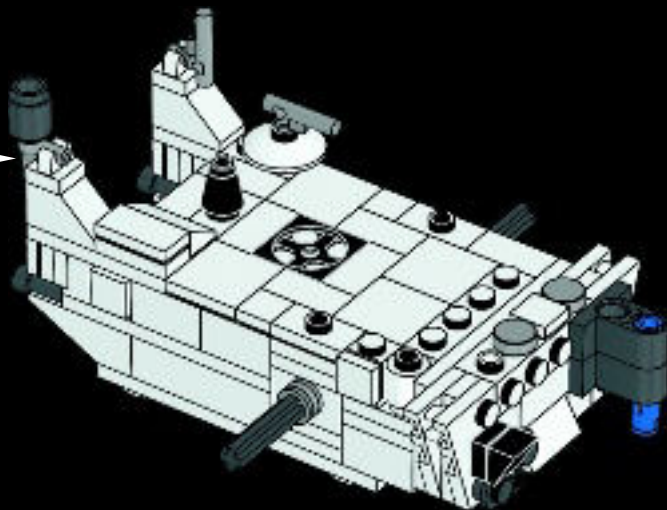
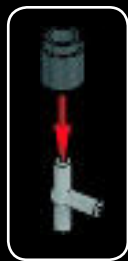



1x



31

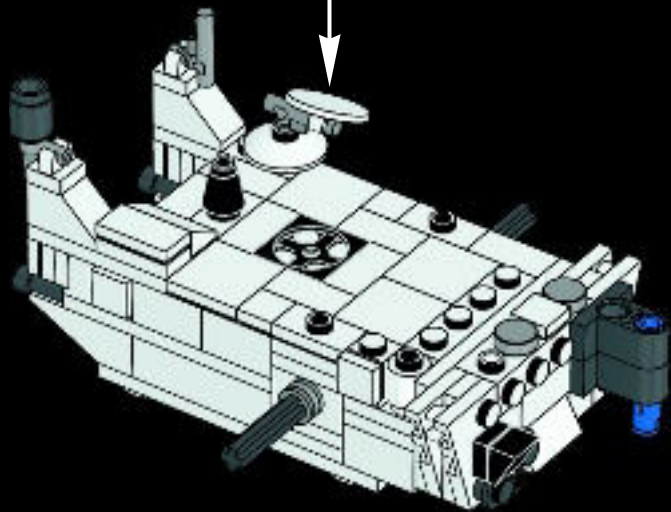



2x



1x

32

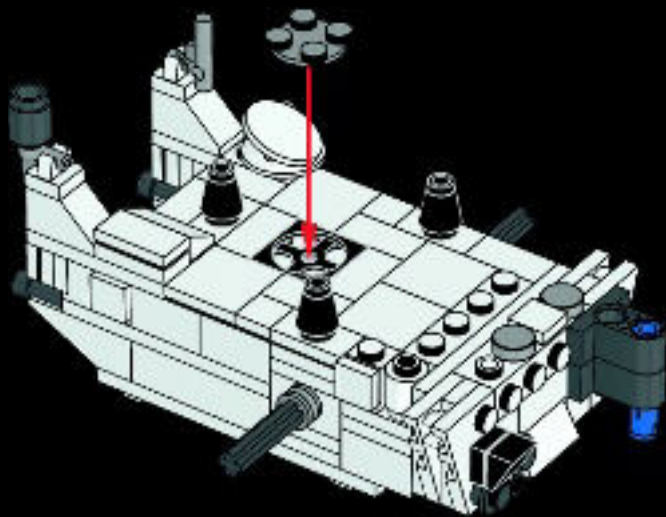



1x



2x

33

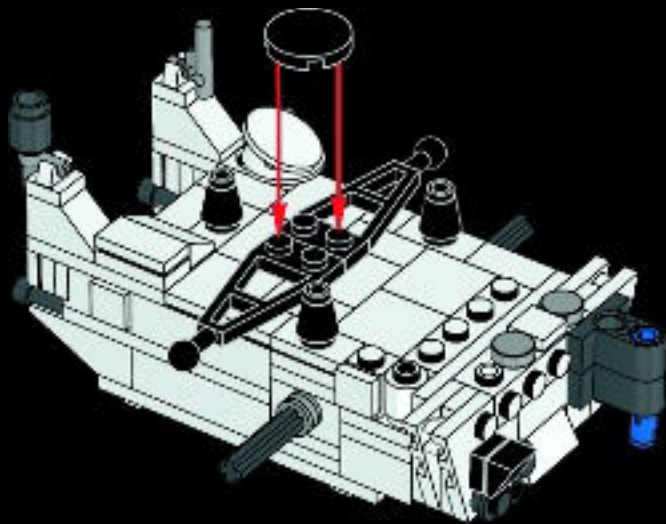



34

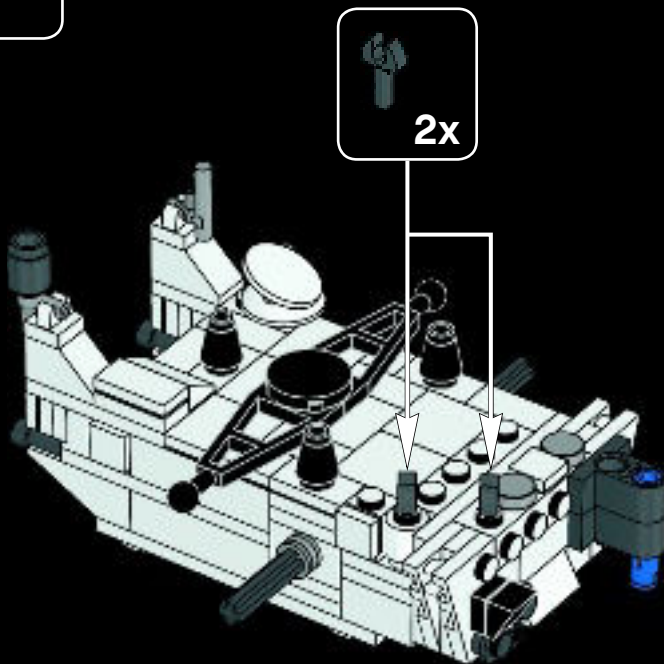

© NASA/JPL-Caltech.

Curiosity has a mass of 1,980 lb. (899 kg), including 180 lb. (80 kg) of scientific instruments. It is 9.5 ft. (2.9 m) long by 8.9 ft. (2.7 m) wide by 7.2 ft. (2.2 m) in height.

Curiosity a une masse de 899 kg, dont 80 kg d'instruments scientifiques. Il mesure 2,9 m de long, 2,7 m de large et 2,2 m de hauteur.

El Curiosity pesa 899 kg, 80 de los cuales corresponden a instrumental científico. Posee 2,9 m de longitud, 2,7 m de anchura y 2,2 m de altura.



35

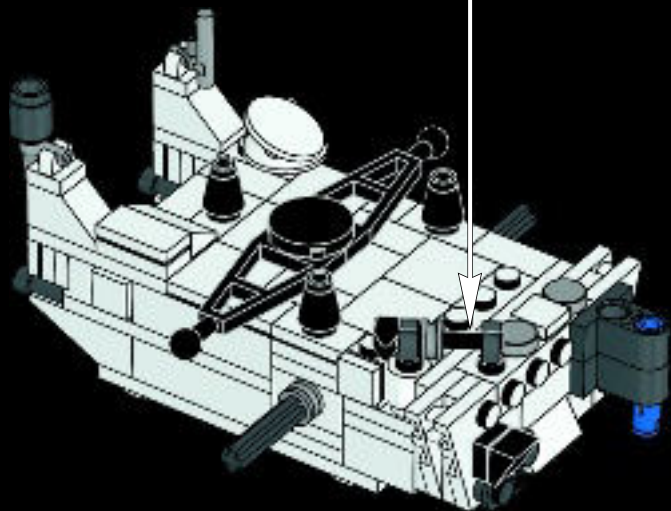

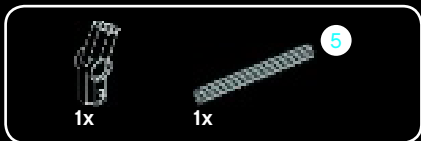

1

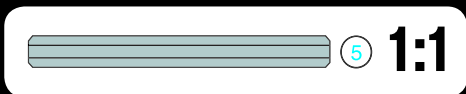



2

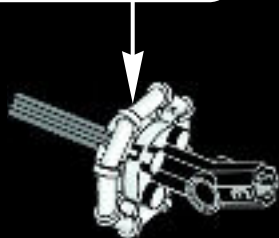
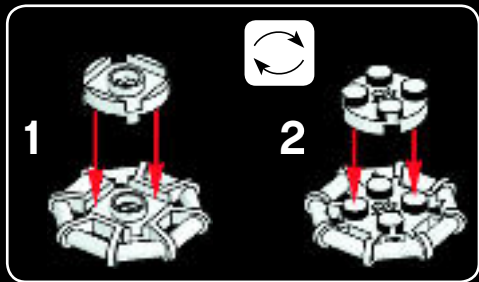

3





4



2



3

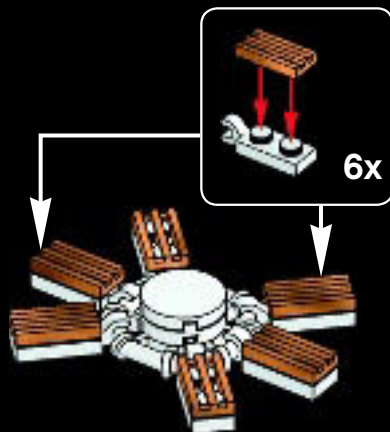

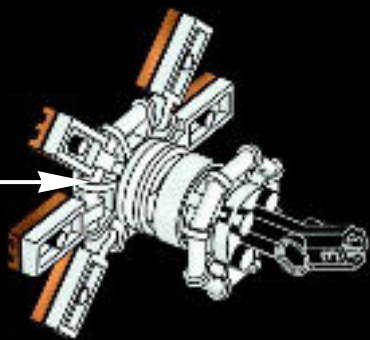

5

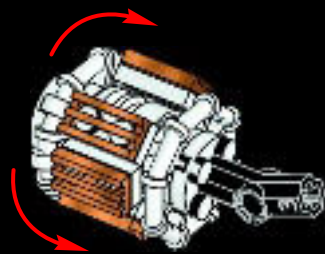

36

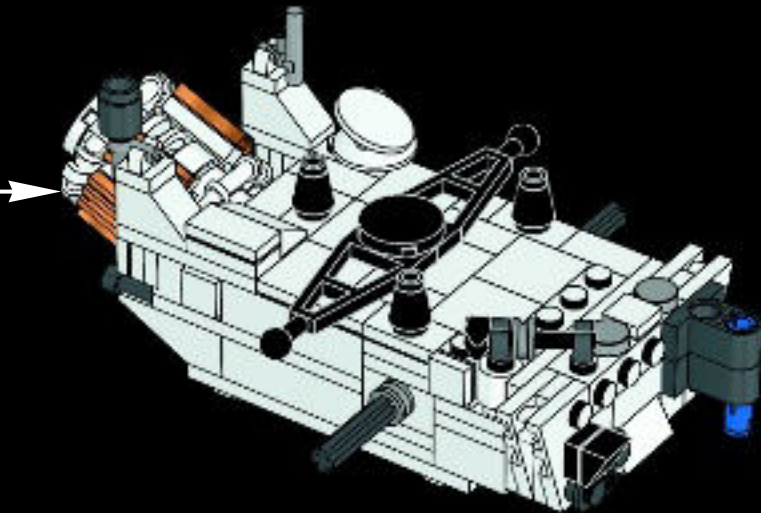

© NASA/JPL-Caltech.

The rover's nuclear power source will last much longer than the designed mission lifetime of one Martian year (almost two Earth years).

La source d'énergie nucléaire du rover durera beaucoup plus longtemps que la durée de la mission, qui est d'une année martienne (presque deux années terrestres).

La fuente de energía nuclear del rover se agotará mucho tiempo después de que la misión, de un año marciano de duración (casi dos años terrestres), llegue a su fin.

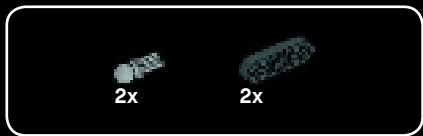

37

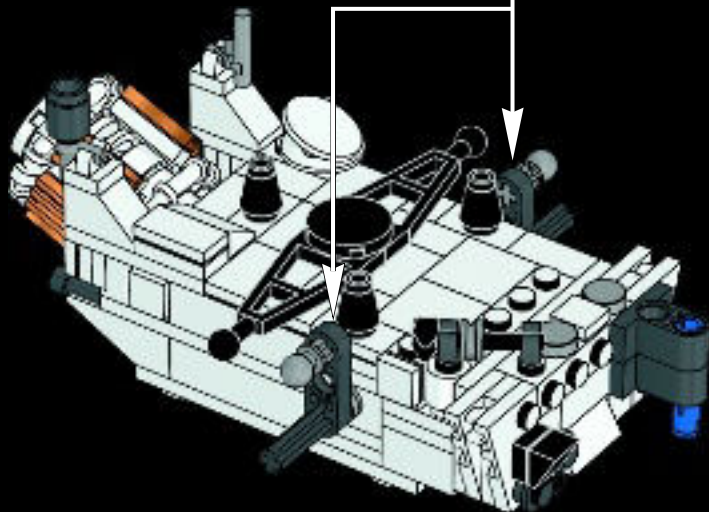



2x

38

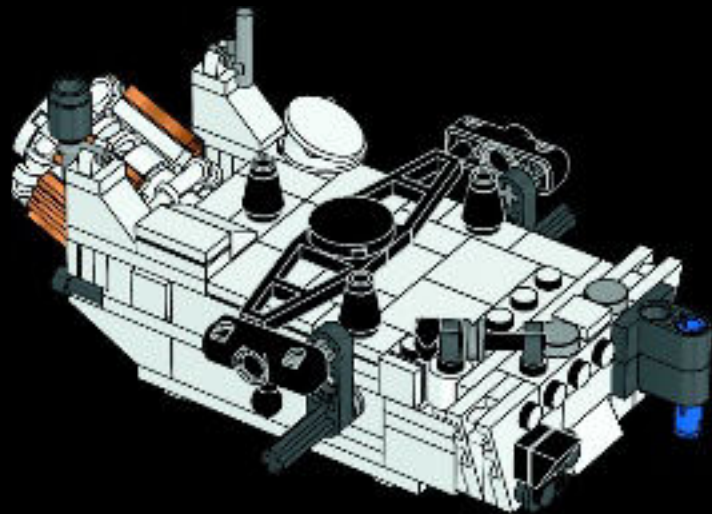

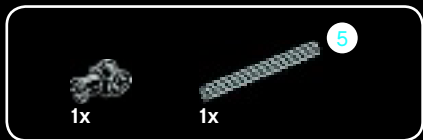

1

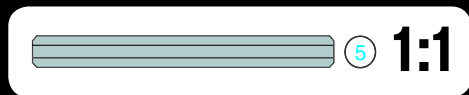

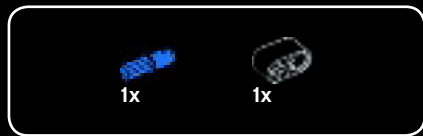

2

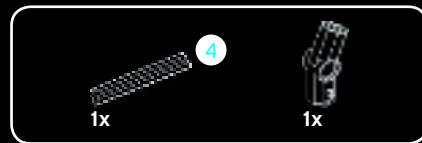
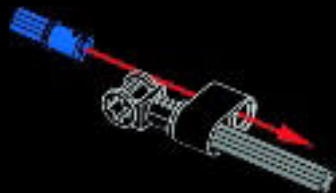

3

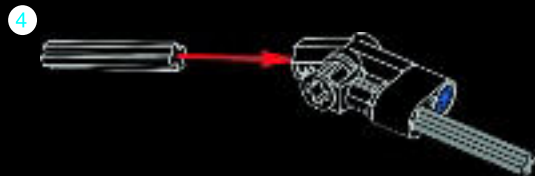



2x



2x

4

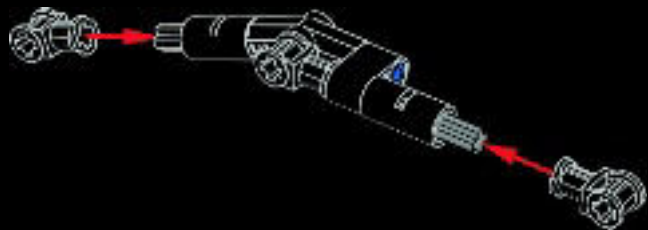

1x

5





6

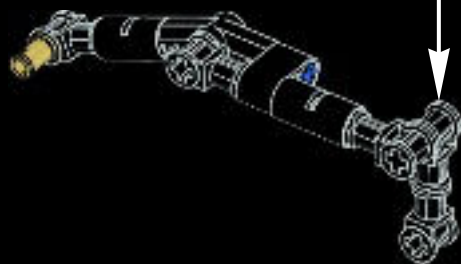
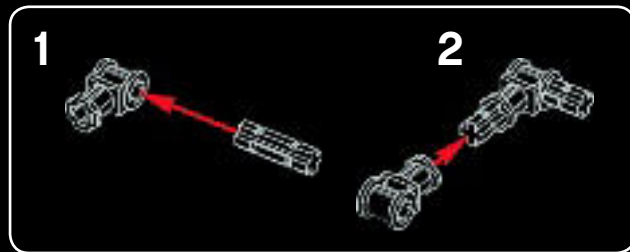



7

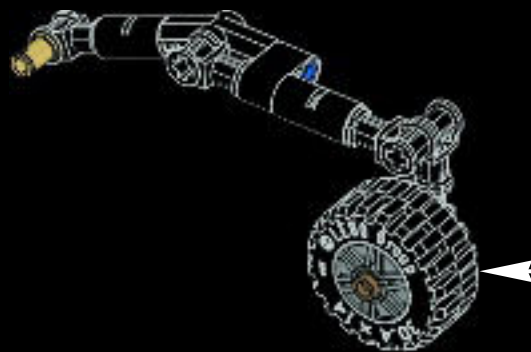
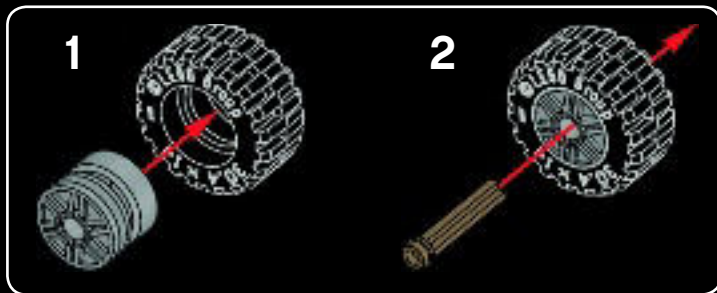



8

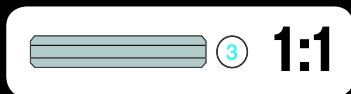
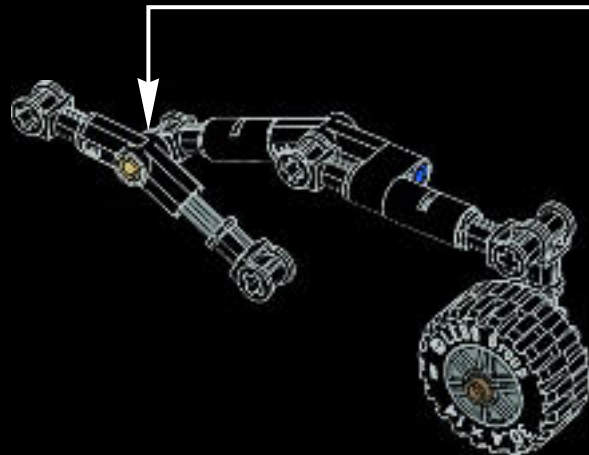
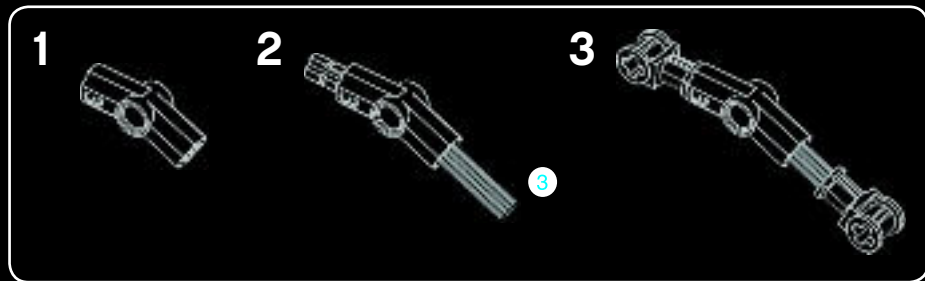



9

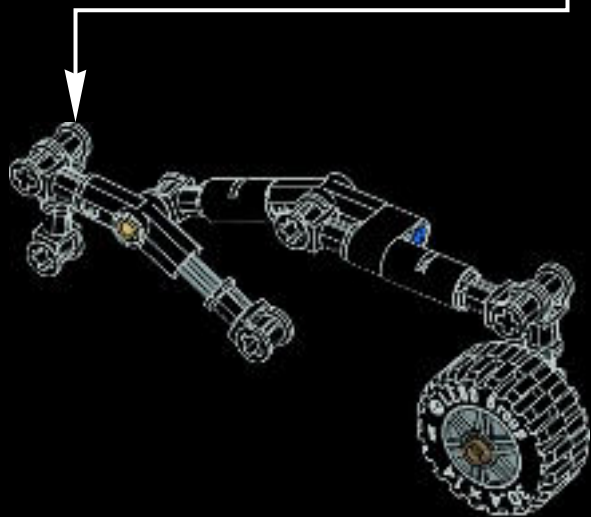
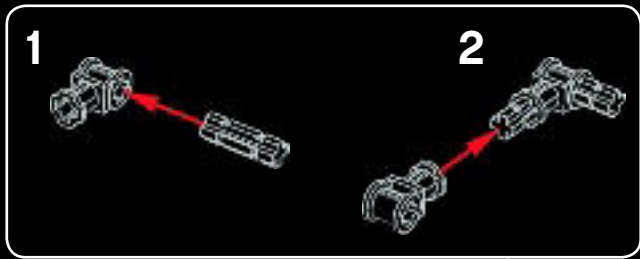



10

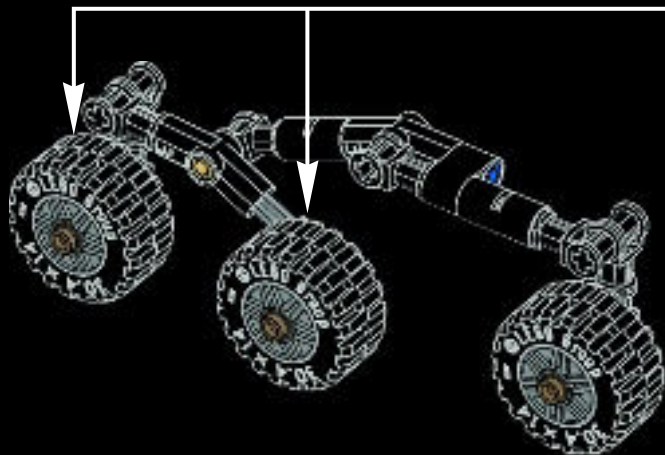
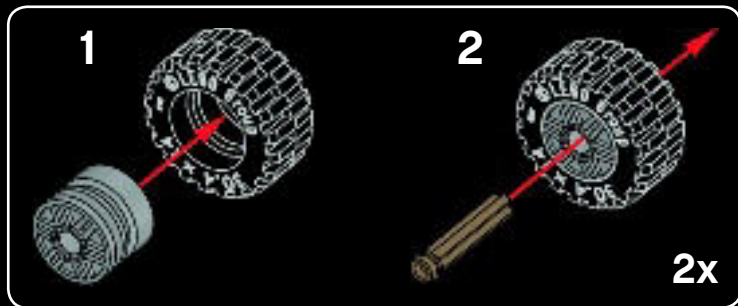

39

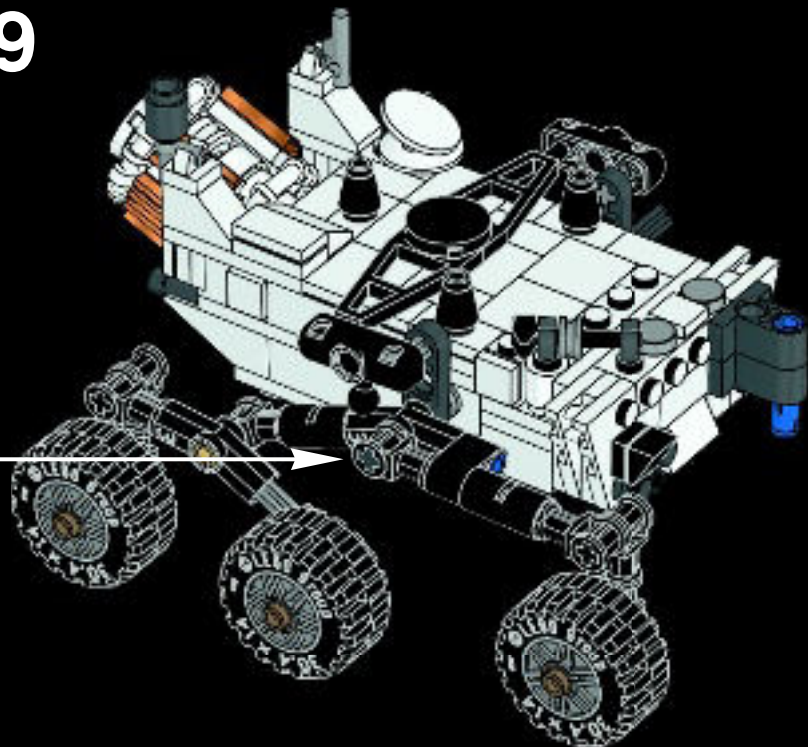

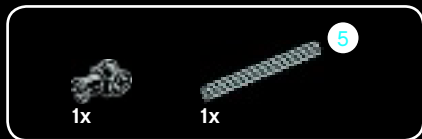

1

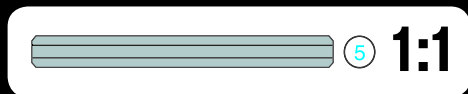

2



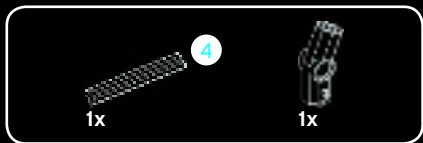

3





2x



2x

4

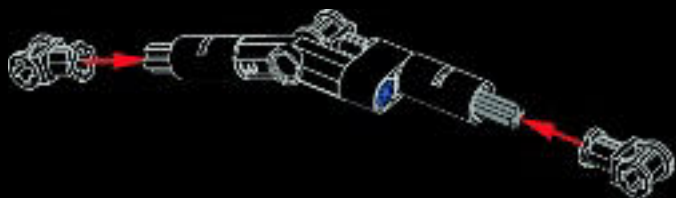

1x

5





6

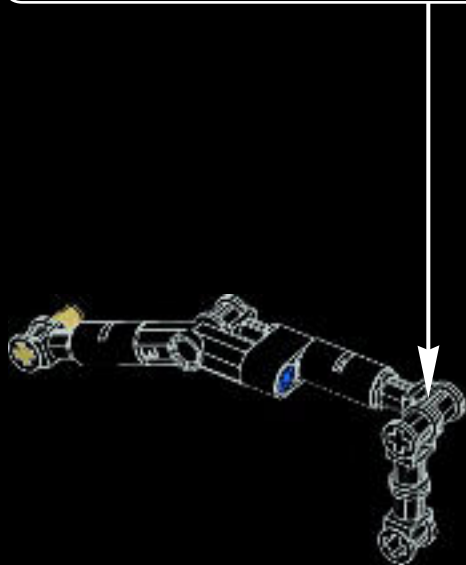
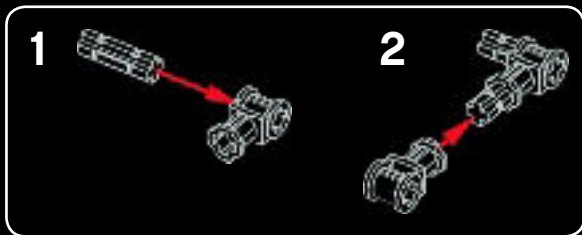



7

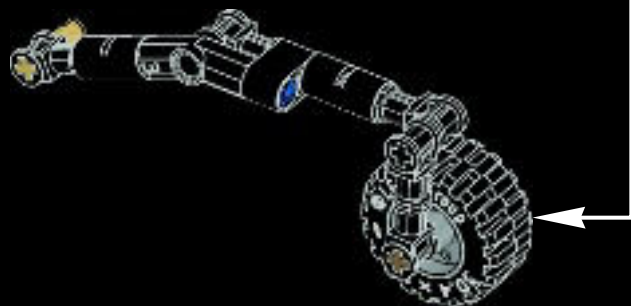
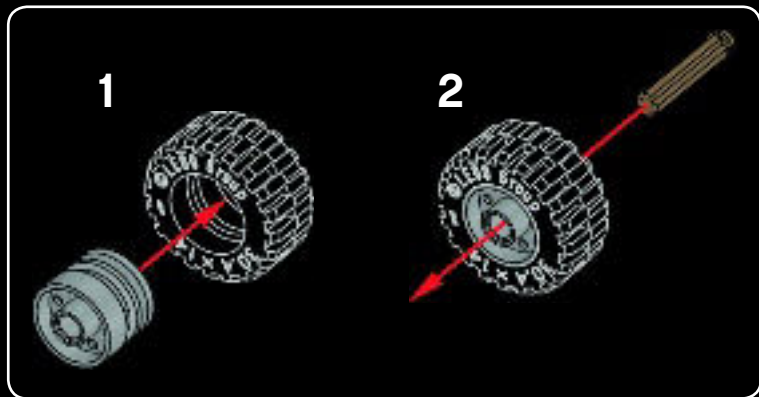

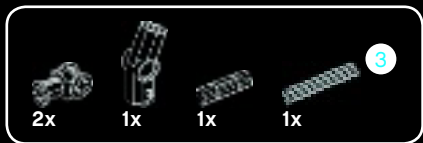

8

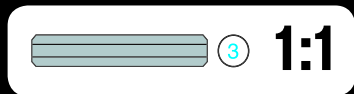
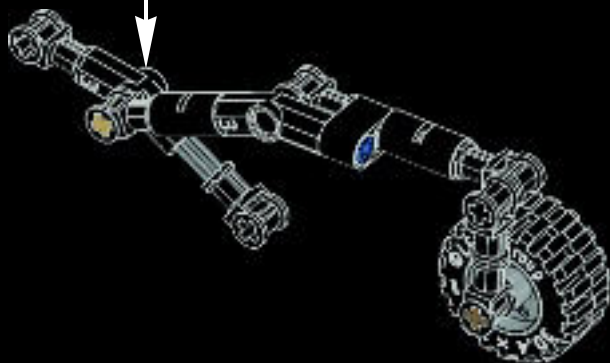
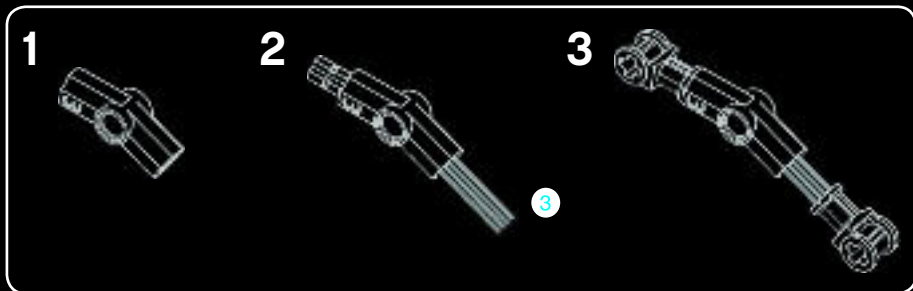



9

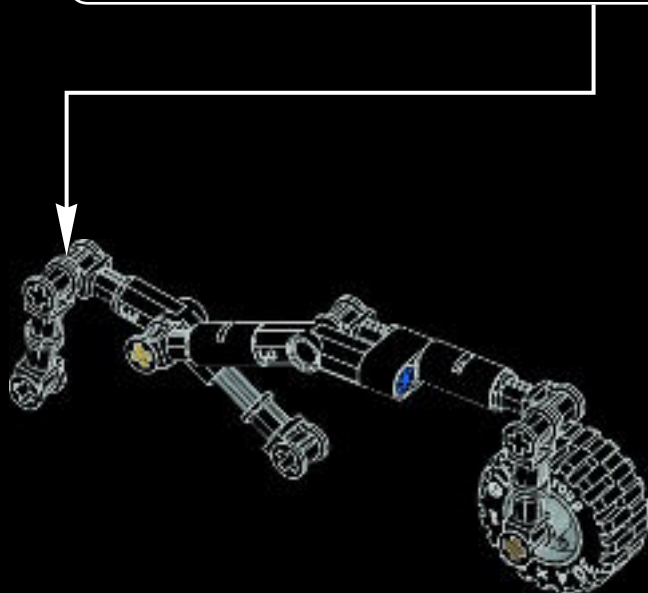
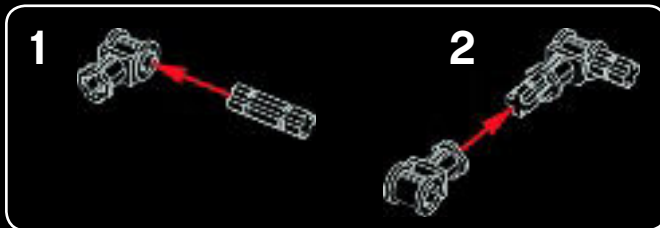

© NASA/JPL-Caltech.

The rocker-bogie suspension system keeps all six wheels on the ground.

Le système de suspension « rocker-bogie » maintient les six roues au sol.

El sistema de suspensión basado en bogies permite mantener siempre las seis ruedas en contacto con la superficie.



10

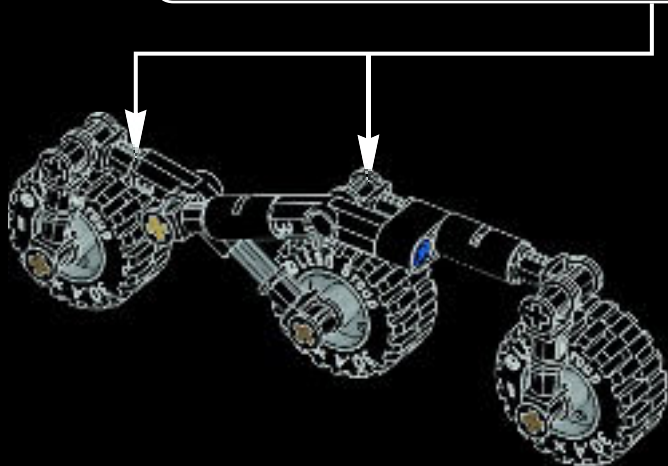
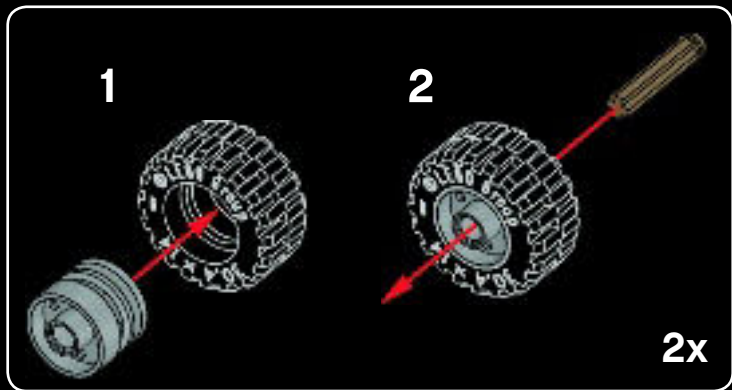

40

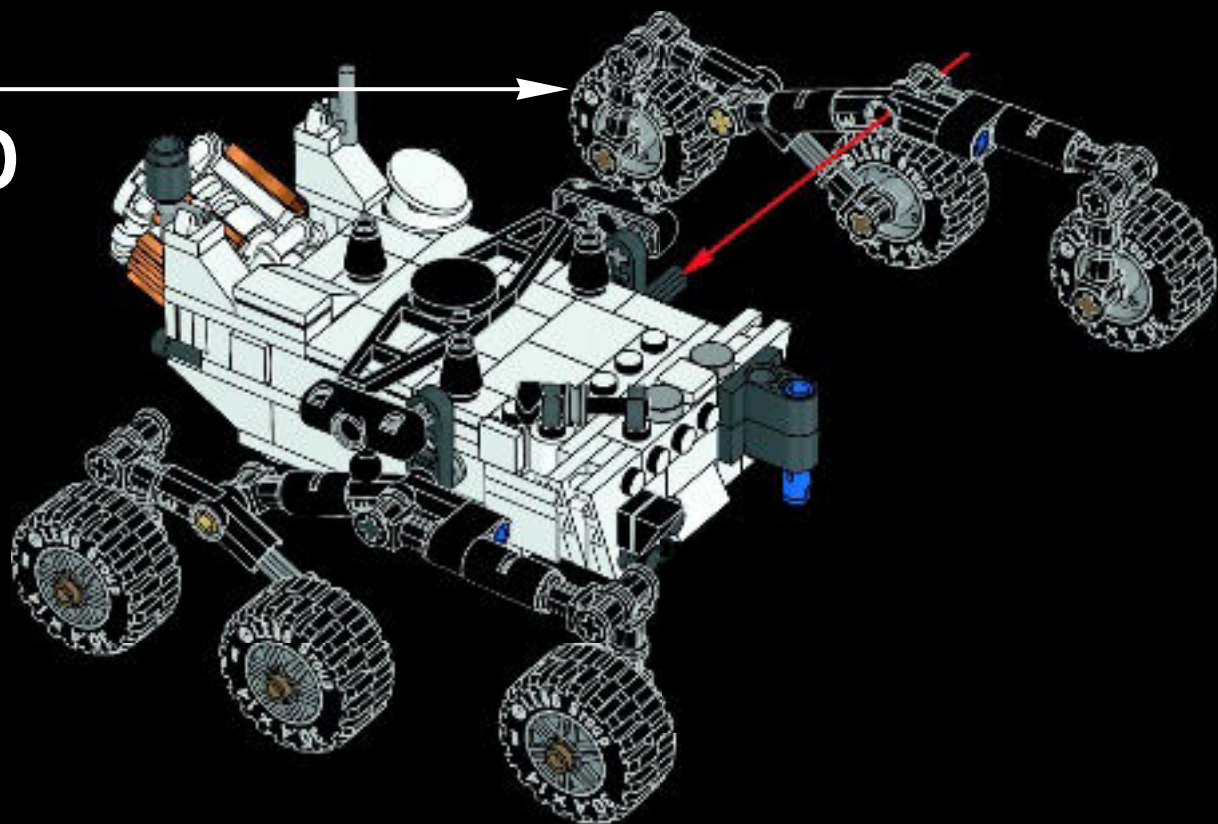



1x



1x



1x



1x

41

1



2



3



4

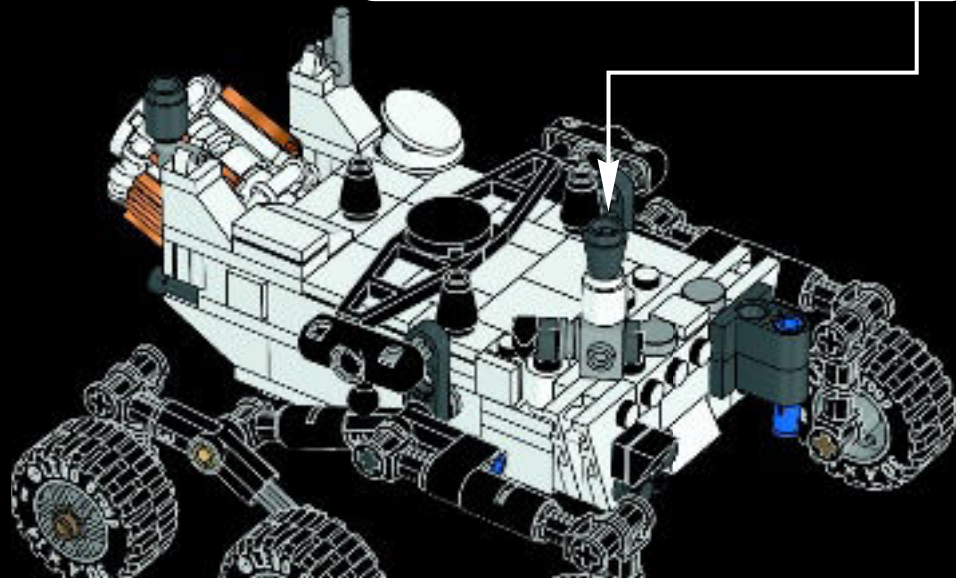



42

1



2



3



© NASA/JPL-Caltech.

The Mast Camera is mounted at eye-level and captures images of the rover's surroundings.

La caméra Mast est montée au niveau des yeux et capte des images de l'environnement du rover.

La cámara de mástil se encuentra a una altura equivalente a la de los ojos de un ser humano y captura imágenes del entorno del rover.

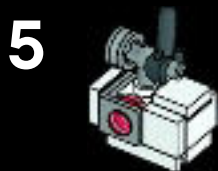
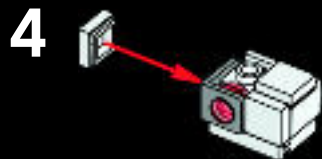
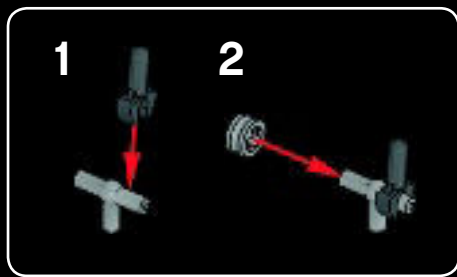

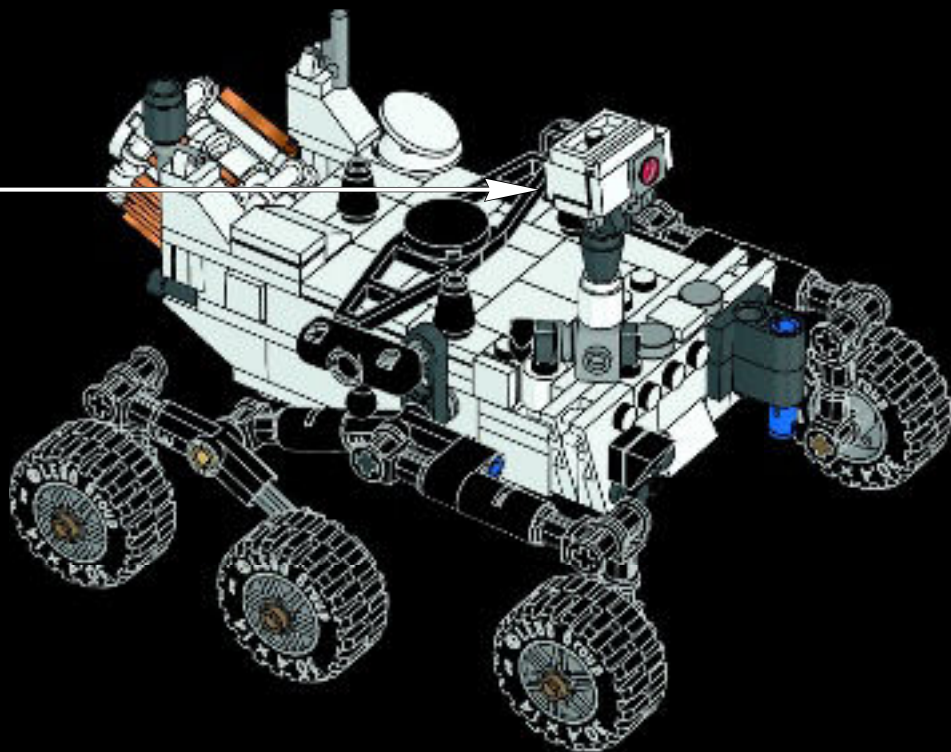

© NASA/JPL-Caltech.

The ChemCam uses laser pulses to vaporize thin layers of material from rock or soil targets up to 23 ft. (7 m) away.

La ChemCam utilise des impulsions laser pour vaporiser de fines couches de matériaux à partir de cibles situées dans la roche ou le sol, avec une portée allant jusqu'à 7 mètres.

La cámara ChemCam usa impulsos láser para vaporizar finas capas de roca o tierra desde distancias de hasta 7 m.



1



2

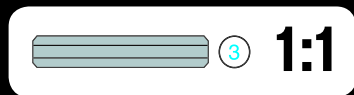
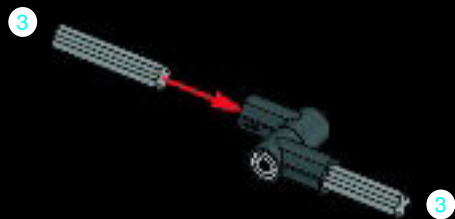



2x



2x

3

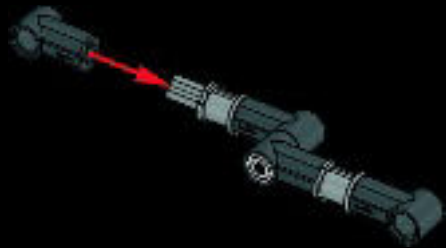

2x



2x

4





1x

5

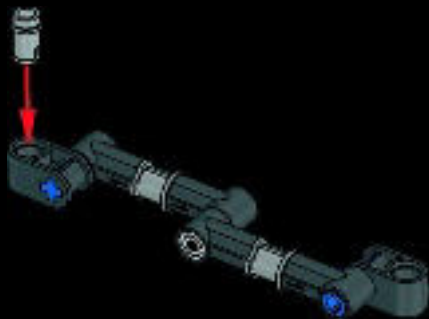



1x

1



1x



1x

2





1x

3



2x

4





5



6





1x

7



8

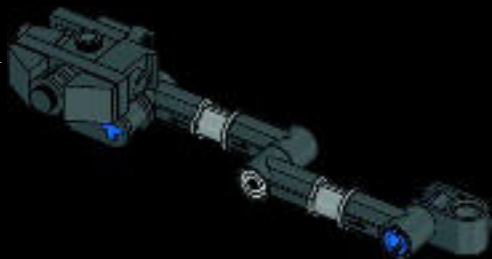

43

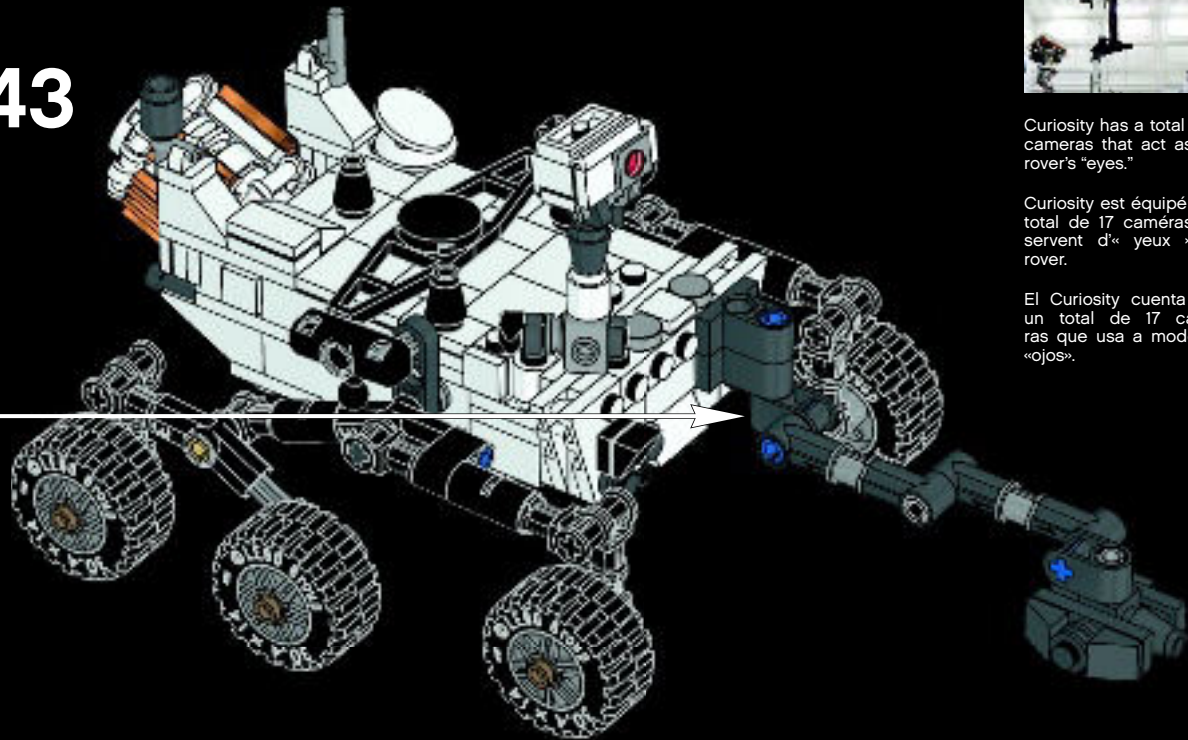

© NASA/JPL-Caltech.

Curiosity has a total of 17 cameras that act as the rover's "eyes."

Curiosity est équipé d'un total de 17 caméras qui servent d'« yeux » au rover.

El Curiosity cuenta con un total de 17 cámaras que usa a modo de «ojos».

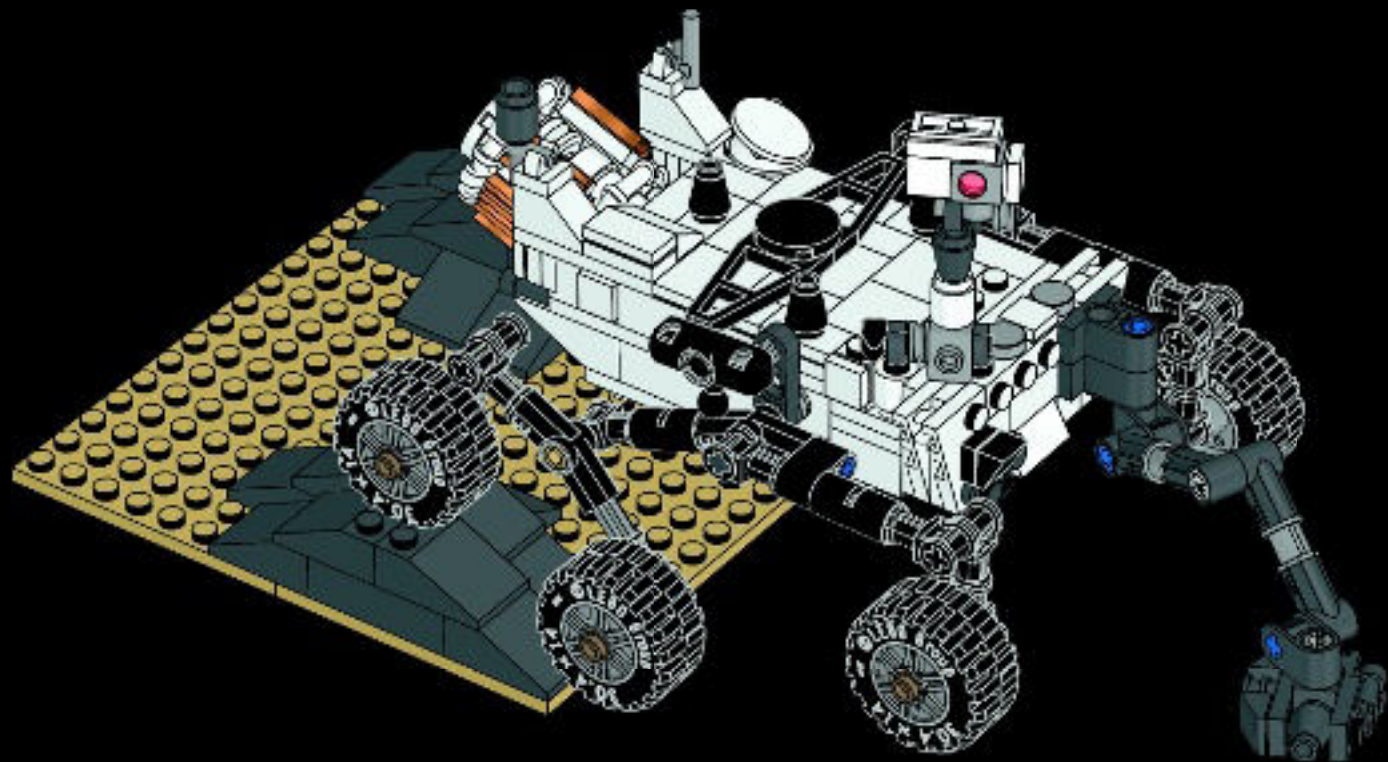

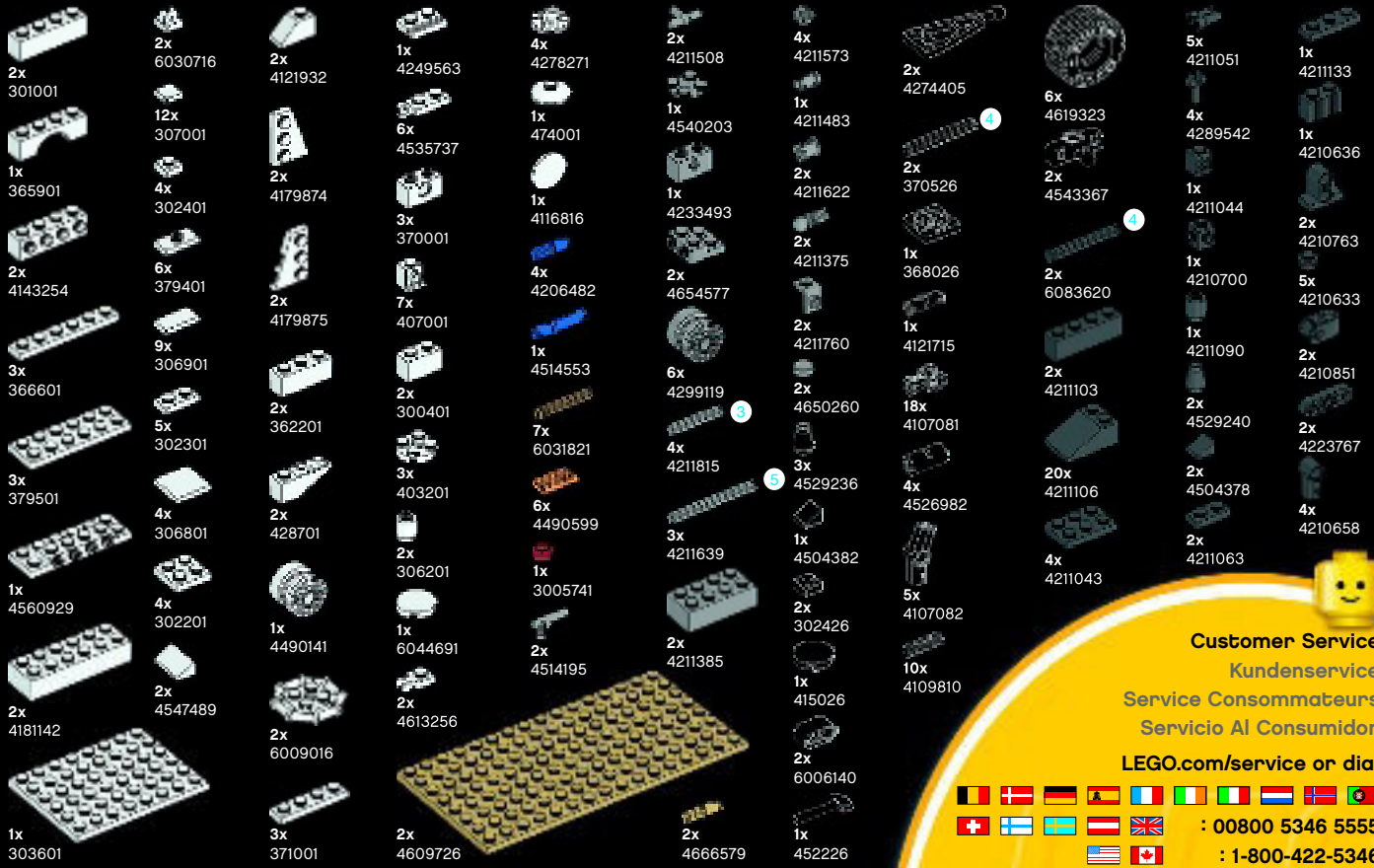

Customer Service
Kundenservice
Service Consommateurs
Servicio Al Consumidor
LEGO.com/service or dial



MY OWN MISSION



Stephen Pakbaz

A WORD FROM THE MODEL CREATOR

“I am a Mechanical Engineer who worked on the actual Curiosity rover at the Jet Propulsion Laboratory. I combined this first-hand experience with my LEGO® hobby to create a LEGO® model that was as faithful to the actual rover as possible in terms of accuracy, details, and mechanical function, while remaining at a reasonable size.”

“The primary purpose of this effort has been to contribute to the educational outreach for this incredible mission. It is my hope that this model encourages the public support that is integral to the continued development and exploration of outer space.”

Once it was decided that the Curiosity model was going to be produced, a team of experienced LEGO® designers evaluated the design and suggested some minor improvements to ensure a LEGO® building experience that matches the standards of our own designs.

LEGO.Cuusoo.com

A PLAYGROUND FOR INNOVATIVE LEGO® IDEAS

Do you have an exciting LEGO® idea? Then why not make it into a LEGO® Cuusoo project? You can share your product concept on LEGO.cuusoo.com and see what other people think about it.

If your project gains 10,000 supporters, it will automatically qualify for the LEGO® Review. This is where we take an in-depth look at the most popular projects and carefully evaluate them to discover the ideas with the most potential. If your project makes it through the review, it could become an official LEGO® product.

There are already over 250,000 active users and 15,000 projects on the Cuusoo website, and three LEGO® Cuusoo products have already been launched. So take a look, sign up, and support your favorite ideas. Or even better—upload your own project!



MA PROPRE MISSION



Stephen Pakbaz

UN MOT DU CRÉATEUR DU MODÈLE

« Je suis ingénieur mécanique et j'ai travaillé sur le véritable rover Curiosity au Jet Propulsion Laboratory. J'ai combiné cette expérience pratique avec ma passion pour les modèles LEGO® pour créer un modèle LEGO® aussi fidèle que possible au rover réel en termes de précision, de détails et de fonction mécanique, tout en conservant une taille raisonnable. »

« L'objectif principal de cette réalisation a été de contribuer à la portée pédagogique de cette mission incroyable. J'espère que ce modèle encouragera le soutien du public, qui est essentiel pour le développement continu et l'exploration spatiale. »

Après avoir décidé que le modèle Curiosity allait être produit, une équipe de designers LEGO® expérimentés a évalué la conception et suggéré quelques améliorations mineures pour fournir une expérience de construction LEGO® conforme aux normes de nos propres modèles.

LEGO.Cuusoo.com

UN ESPACE POUR LES IDÉES LEGO® NOVATRICES

As-tu une idée LEGO® passionnante ? Alors pourquoi ne pas en faire un projet LEGO® Cuusoo ? Tu peux partager ton concept de produit sur LEGO.cuusoo.com et voir ce que les autres en pensent.

Si ton projet obtient l'appui de 10 000 personnes, il sera automatiquement qualifié pour un examen LEGO®. Cet examen nous permet d'étudier en profondeur les projets les plus populaires et de les évaluer attentivement pour découvrir les idées ayant le plus grand potentiel. Si ton projet passe l'examen, il pourrait devenir un produit LEGO® officiel.

Il y a déjà 250 000 utilisateurs actifs et 15 000 projets sur le site Web Cuusoo et trois produits LEGO® Cuusoo ont déjà été lancés. Alors va regarder, inscris-toi et soutiens tes idées préférées. Ou mieux encore : télécharge ton propre projet !



MI PROPIA MISIÓN



Stephen Pakbaz

OBSERVACIONES DEL CREADOR DEL MODELO

«Soy ingeniero mecánico y trabajé en el auténtico Curiosity en el Laboratorio de Propulsión a Chorro. Combiné la experiencia que adquirí de primera mano con mi afición a construir con LEGO® para crear un modelo LEGO® que fuese lo más fiel posible al rover real en términos de precisión, detalles y funciones mecánicas, a una escala razonable».

«El principal objetivo de este esfuerzo es fomentar la faceta educativa de esta increíble misión. Espero que el modelo atraiga el apoyo del público hacia la misión, algo fundamental para el desarrollo y la exploración del espacio exterior».

Una vez que se confirmó la fabricación del modelo basado en el Curiosity, un equipo de diseñadores expertos de LEGO® evaluó el diseño y sugirió un par de cambios para garantizar que la experiencia de construcción estuviera a la altura del resto de modelos LEGO®.

LEGO.Cuusoo.com

LEGO.CUUSOO.COM: EL LUGAR EN EL QUE SE REÚNEN LAS IDEAS LEGO®

¿Tienes una buena idea para un modelo LEGO®? ¿Por qué no convertirla en un proyecto LEGO® Cuusoo? Puedes compartir tu idea en LEGO.cuusoo.com y ver lo que los demás piensan de ella.

Si tu proyecto consigue 10.000 votos, se clasificará automáticamente para la revisión trimestral de LEGO®. Es entonces cuando daremos un vistazo a los proyectos más populares y los evaluaremos detenidamente para determinar qué idea tiene más potencial. Si tu proyecto supera la revisión, se convertirá en un producto LEGO® oficial.

Ya hay más de 250.000 usuarios activos y 15.000 proyectos en el sitio web de Cuusoo. Además, tres proyectos LEGO® Cuusoo se han convertido ya en productos reales y han salido a la venta. Ven a dar un vistazo, regístrate y apoya tus ideas favoritas. O aún mejor: ¡envía tu propio proyecto!





WIN!

Go to LEGO.com/productfeedback to fill out a survey for a chance to win a cool LEGO® Product.

No purchase necessary.
Open to all residents where not prohibited.



LEGO.com/productfeedback

GEWINNE!

Nimm an der Umfrage auf LEGO.com/productfeedback teil und hab die Chance ein cooles LEGO® Produkt zu gewinnen!

Die Teilnahme am Gewinnspiel führt zu keinerlei Kaufverpflichtungen. Teilnahme in allen nicht ausgeschlossenen Ländern möglich.

 LEGO.com

6083687

WIN!

Ga naar LEGO.com/productfeedback, vul een enquêteformulier in en maak kans op een cool LEGO® product.

Geen aankoopverplichting.
Iedereen mag deelnemen, uitgezonderd ingezetenden van landen waar een enquêteverbod geldt.

GAGNE!

Visite LEGO.com/productfeedback pour répondre à un questionnaire et avoir une chance de gagner un produit LEGO® très cool!

Aucune obligation d'achat.
Ouvert à tous les résidents des pays autorisés.

当てよう!

LEGO.com/productfeedback にアクセスして、アンケートにご記入ください。当選者にはレゴ®製品を差し上げます。

お買い上げの必要はありません。
禁止されていない限り、すべての皆様にご利用いただけます。

LEGO and the LEGO logo are trademarks of the/son des marques de commerce de/son marcas registradas de LEGO Group. ©2014 The LEGO Group.